

Operating manual

multi N/C 4300 UV
TOC Analyzer



Manufacturer Analytik Jena GmbH+Co. KG
Konrad-Zuse-Straße 1
07745 Jena / Germany
Phone: +49 3641 77 70
Fax: +49 3641 77 9279
Email: info@analytik-jena.com

Technical Service Analytik Jena GmbH+Co. KG
Konrad-Zuse-Straße 1
07745 Jena / Germany
Phone: +49 3641 77 7407
Fax: +49 3641 77 9279
Email: service@analytik-jena.com



To ensure correct and safe use, follow these instructions. Keep these instructions for later reference.

General information <http://www.analytik-jena.com>

Documentation number 11-0118-008-23

Edition E (10/2025)

Technical documentation Analytik Jena GmbH+Co. KG

© Copyright 2025, Analytik Jena GmbH+Co. KG

Table of contents

1	Basic information	7
1.1	About this user manual	7
1.2	Intended use	7
2	Safety.....	9
2.1	Safety labeling on the device	9
2.2	Requirements for the operating personnel.....	10
2.3	Safety instructions, transport and commissioning	10
2.4	Safety instructions: during operation	11
2.4.1	Summary of safety instructions	11
2.4.2	Safety instructions – protection against explosion and fire.....	12
2.4.3	Electrical system safety instructions	12
2.4.4	Safety instructions for the operation of compressed gas containers and compressed gas systems.....	12
2.4.5	Safety notes on UV radiation	13
2.4.6	Handling of auxiliary and operating materials	13
2.4.7	Safety instructions – maintenance and repair.....	13
2.5	Behavior during emergencies	14
3	Function and design	15
3.1	Layout.....	15
3.1.1	Sample supply system	16
3.1.2	Hose system	17
3.1.3	UV reactor with control gear	19
3.1.4	Measuring gas drying and cleaning.....	20
3.1.5	Detection.....	22
3.1.6	Indicator and control elements, connections.....	22
3.1.7	Reagents and accessories.....	23
3.2	Additional options for the analyzer	24
3.3	Function and measuring principle	24
3.4	Measuring methods	26
3.4.1	TC analysis.....	26
3.4.2	TOC analysis.....	26
3.4.3	TIC analysis.....	26
3.4.4	NPOC analysis	26
3.4.5	DOC analysis.....	27
3.4.6	Additional sum parameters.....	27
3.5	Calibration.....	28
3.5.1	Calibration strategies.....	28
3.5.2	Daily factor	28
3.5.3	Calibration method.....	29
3.5.4	Method characteristics	30
3.5.5	Other calculations.....	30
3.6	Blank values	31
3.6.1	Water blank values	31
3.6.2	Reagent blank value	32
3.6.3	Eluate blank value	32
3.6.4	Boat blank value	32
3.7	System suitability test.....	33

4	Installation and commissioning	34
4.1	Installation conditions	34
4.1.1	Ambient conditions	34
4.1.2	Device layout and space requirements	34
4.1.3	Power supply	35
4.1.4	Gas supply	35
4.2	Unpacking and setting up the device	35
4.2.1	Installing and commissioning the analyzer	36
4.3	Connecting accessories	39
4.3.1	The AS 10e and AS 21hp autosamplers	39
4.3.2	AS vario autosampler	47
4.3.3	EPA Sampler	53
4.3.4	External solids module	57
5	Operation	59
5.1	General notes	59
5.2	Switching on the analyzer	60
5.3	Switching off the analyzer	61
5.4	Performing measurements	62
5.4.1	Create sequence and measure with manual sample feed	62
5.4.2	Creating a sequence and measuring with automatic sample feed	64
6	Maintenance and care	67
6.1	Maintenance overview	67
6.2	Adjustment and setting	68
6.2.1	General notes for adjusting the autosampler	68
6.2.2	Adjusting the AS vario autosampler	68
6.2.3	Adjusting the EPA Sampler	70
6.2.4	Setting the NPOC purge flow	73
6.3	Syringe pump maintenance	74
6.4	Replacing the pump hose	75
6.5	Replacing the hose connections	76
6.6	Checking the system for leaks	78
6.7	UV reactor maintenance	78
6.7.1	Checking the illumination of the lamp	79
6.7.2	Cleaning the UV reactor	79
6.8	Cleaning the TIC condensate vessel	80
6.9	Replacing the water traps	81
6.10	Replacing the halogen trap	83
7	Troubleshooting	85
7.1	Software error messages	85
7.2	Status errors	89
7.3	Device errors	90
8	Transport and storage	93
8.1	Transport	93
8.1.1	Preparing the analyzer for transport	93
8.1.2	Preparing the AS vario autosampler for transport	94
8.1.3	Moving the device in the laboratory	95

8.2	Storage	95
9	Disposal	96
9.1	Disposing of the UV module.....	96
10	Specifications.....	99
10.1	Technical data of the basic device	99
10.2	Technical data of the accessories	100
10.3	Standards and directives	102

1 Basic information

1.1 About this user manual

Content	<p>The operating manual describes the following device model(s):</p> <ul style="list-style-type: none"> ▪ multi N/C 4300 UV <p>The device is intended to be operated by qualified specialist personnel under observance of the operating manual.</p> <p>The operating manual provides information about the design and operation of the device and provides operating personnel with the necessary know-how for safe handling of the device and its components. Furthermore, the operating manual includes information on the maintenance and servicing of the device as well as information on potential causes of malfunctions and their correction.</p>
Conventions	<p>Instructions for actions occurring in chronological order are numbered and combined into action units.</p> <p>Warnings are indicated by a warning triangle and a signal word. The type, source and consequences of the hazard are stated together with notes on preventing the hazard.</p> <p>Elements of the control and analysis program are indicated as follows:</p> <ul style="list-style-type: none"> ▪ Program terms are in bold (e.g., the System menu). ▪ Menu items are separated by vertical lines (e.g., System Device).
Symbols and signal words used in this manual	<p>The user manual uses the following symbols and signal words to indicate hazards or instructions. These warnings are always placed before an action.</p>



WARNING

Indicates a potentially hazardous situation which can cause death or very serious (possibly permanent) injury.



CAUTION

Indicates a potentially hazardous situation which can cause slight or minor injuries.



NOTE

Provides information on potential material or environmental damage.

1.2 Intended use

The device and its components may only be used for the analyses listed in the user manual. Only this specified use is regarded as the intended use, ensuring the safety of the user and the device.

The analyzer may only be used to determine the total carbon content and the concentration of organic and inorganic bound carbon in aqueous samples.

The analyzer is particularly suited for detection of the listed parameters in drinking water, ground water, surface water, ultrapure water and water for pharmaceutical purposes.

In conjunction with an optional solids module, the total carbon content in solids can be determined.

No flammable liquids or substances that can form explosive mixtures may be analyzed with the analyzer. Do not analyze concentrated acids with the analyzer!

The device must only be used with nitrogen or argon as a carrier gas. Oxygen or synthetic air may not be used as carrier gas. The UV radiation would generate ozone from oxygen.







2 Safety

2.1 Safety labeling on the device

Warning and mandatory action labels have been attached to the device and must always be observed.







Damaged or missing warning and mandatory action labels can cause incorrect actions leading to personal injury or material damage. The labels must not be removed. Damaged warning and mandatory action labels must be replaced immediately!

The following warning and mandatory action labels have been attached to the device:

Warning symbol	Meaning	Comment
	Warning against corrosive substances	On the front side, next to the syringe pump: Warning against acidic solutions
	Warning against harmful or irritating substances	On the front side, next to the syringe pump: Warning against acidic and harmful solutions
	Warning against mercury	In the device interior, on the UV reactor: The UV reactor is equipped with a low-pressure mercury lamp. Observe this during disposal!
	Warning against optical radiation	On the UV reactor: UV radiation is damaging to the eyes. Switch off the analyzer before removing the UV module.
	Warning against hot surface	On the UV reactor: Risk of burns from the hot UV reactor. Allow the analyzer to cool before removing the UV module.
	Warning against crushing	On the autosampler: There is a risk of injury in the movement range of the autosampler.
	Warning of sharp objects	On the autosampler: There is a risk of puncture injuries on the autosampler canula

Hazardous substances are used during operation:

GHS labeling	Meaning	Comment
	Corrosivity warning	<ul style="list-style-type: none"> On the phosphoric acid bottle: On the sodium persulfate bottle: Phosphoric acid and the sulfuric acid contained in the sodium persulfate solution are corrosive.

GHS labeling	Meaning	Comment
	Hazardous substances warning	On the sodium persulfate bottle: Sodium persulfate is a strong oxidizing agent. It is hazardous to health when ingested and causes irritation of the skin, eyes and respiratory pathways. Contact can cause allergic reactions, respiratory problems or asthma-like symptoms.
	Health hazard	
	Warning against fire-promoting substances	
Mandatory signs/ information symbols	Meaning	Comment
	Disconnect the power supply before opening the device cover	On the side parts and the rear of the device: Before opening the device cover, switch off the device and disconnect the mains plug from the mains socket.
	Observe the operating manual	On the side parts and the rear of the device: Before starting work, read the operating manual.
	For People's Republic of China only	The device contains controlled substances. Analytik Jena warrants that these substances will not be released from the device within the next 25 years provided the device is employed as intended.

2.2 Requirements for the operating personnel

The device must only be operated by qualified specialist personnel instructed in the use of the device. This instruction also include teaching the contents of this user manual and of the user manuals of the connected system components. We recommend training by qualified employees of Analytik Jena or its representatives.

In addition to the safety instructions in this user manual, the general applicable safety and accident prevention regulations of the respective country the device is operated in must be observed and adhered to. The operator must ensure the latest version of these regulations.

The user manual must be accessible to the operating and service personnel.

2.3 Safety instructions, transport and commissioning

Incorrect installation can create serious hazards. This may result in electric shock and explosion if the gases are not connected correctly.

- Only the Analytik Jena customer service or specialist personnel trained and authorized by them is allowed to install and commission the device and its system components.
- Unauthorized assembly and installation is not permitted.

Insufficiently secured components pose a risk of injury.

- During transport, secure the device components as specified in these operating instructions.
- Loose parts must be removed from the system components and packed separately.

To prevent health damage, the following must be observed when moving the device in the laboratory (lifting and carrying):

- For safety reasons, two persons are required to transport the device who must hold the unit by either side of the equipment.
- The device does not have any carrying handles. Therefore the device must be gripped firmly with both hands at the lower end.
- Risk of damage to health due to improper decontamination! Perform a professional and documented decontamination of the device before returning it to Analytik Jena. The decontamination report is available from Service when registering the return. Without a completed decontamination report, the acceptance of the device will be refused. The sender may be liable for damage caused by inadequate decontamination of the device.

2.4 Safety instructions: during operation

2.4.1 Summary of safety instructions

The operator must make sure that the device and its safety equipment is in sound condition each time before starting up the device. This applies in particular after each modification or extension of the device or its repair.

Observe the following:

- The device may only be operated if all items of protective equipment (e.g. covers in front of electronic components) are in place, properly installed and fully operational.
- The sound condition of the protection and safety equipment must be checked regularly. Any defects must be corrected as soon as they occur.
- Protective and safety equipment must never be removed, modified or switched off during operation.
- Always ensure free access to the main switch and to the emergency shutdown switches and locks during operation.
- The ventilation equipment on the device must be in good working condition. Covered ventilation grilles or slots etc. may cause the device to break down or may cause damage to it.
- Modifications, conversions and extensions to the device are only permitted after consultation with Analytik Jena. Unauthorized modifications can jeopardize the device's operational safety and may lead to limitations regarding the warranty and access to customer service.
- Keep all combustible materials away from the device.
- Caution when handling glass components. Risk of broken glass and therefore risk of injury!
- Ensure that no liquid enters the interior of the device, for example at cable connections. There is a danger of electric shock.
- There is a risk of injury in the movement range of the autosampler. For example, hands or fingers may be crushed. Maintain a safety distance from the autosampler during operation.

2.4.2 Safety instructions – protection against explosion and fire

The device may not be operated in an explosive environment.

Smoking or handling open flames are prohibited in the room in which the device is operated!

2.4.3 Electrical system safety instructions

Life-threatening electrical voltages occur in the device in the area of the right side component! Contact with live components may cause death, serious injury or painful electrical shock.

- The power plug must be connected to a proper power outlet to ensure that the device meets protection class I (ground connector). The device may only be connected to power sources whose nominal voltage is the same as that on the rating plate of the equipment. Do not replace the removable power cable of the device with a power cable that does not meet the specifications (with no protective ground conductor). Extensions of the supply cable are not permitted!
- Work on the electronics may only be carried out by the customer service of Analytik Jena and specially authorized technicians.
- The electrical components must be checked regularly by a qualified electrician. Any defects such as loose connections or faulty or damaged cables must be repaired without delay.
- Before opening the device, the device must be switched off via the main switch and the power plug must be disconnected from the power outlet!
- The basic module and the system components may only be connected to the mains when they are switched off.
- Electrical connection cables between the basic module and the system components may only be connected or disconnected when the device is switched off.
- Switch off the analyzer immediately using the main switch on the rear of the housing if there is any malfunction of the electrical components. Disconnect the power plug from the power socket.

2.4.4 Safety instructions for the operation of compressed gas containers and compressed gas systems

- The operating gases are taken from compressed gas containers or local compressed gas systems. The operating gases must have the required purity.
- Work on compressed gas containers and systems may only be carried out by individuals with specialist knowledge and experience in compressed gas systems.
- Compressed air hoses and pressure reducers may only be used for the assigned gases.
- Pipes, hoses, screw connections and pressure reducers for oxygen must be kept free from grease.
- Check all pipes, hoses and screw connections regularly for leaks and externally visible damage. Repair leaks and damage without delay.
- Shut off the gas supply to the device prior to any maintenance and repair work on the compressed gas containers.
- After successful repair and maintenance of the components of the compressed gas containers or system, the device must be checked for proper operation prior to recommissioning.
- Unauthorized assembly and installation are not permitted!

2.4.5 Safety notes on UV radiation

- Protection of the user against UVC radiation is ensured by the protective glass before the UV reactor. The protective glass must not be removed during operation.
- Manipulation of the protective glass is not permitted!
- Avoid looking through the protective glass for too long to protect your eyes.
- Do not use oxygen or synthetic air as a carrier gas. The UVC radiation of the UV reactor will decompose oxygen molecules to oxygen radicals. Reaction with other oxygen molecules would generate ozone. Ozone, the toxic gas, causes damage to mucous membranes.

2.4.6 Handling of auxiliary and operating materials

The operator is responsible for the selection of substances used in the process as well as for their safe handling. This is particularly important for radioactive, infectious, poisonous, corrosive, combustible, explosive and otherwise dangerous substances.

When handling hazardous substances, the locally applicable safety instructions and instructions in the safety data sheets from the manufacturers of the auxiliary and operating materials must be complied with.

- Exercise particular caution when handling concentrated acids and the toxic strong oxidant sodium persulfate. Always observe the regulations and information in the safety data sheets for the handling of orthophosphoric acid (H_3PO_4), sulfuric acid (H_2SO_4) and sodium persulfate ($\text{Na}_2\text{S}_2\text{O}_8$)!

Observe the following:

- The operator is responsible for carrying out suitable decontamination should the device become contaminated externally or internally with dangerous substances.
- Splashes, drops or larger liquid spillages should be removed using an absorbent material such as cotton wool, laboratory wipes or cellulose.
- For biological contamination, wipe the affected area with a suitable disinfectant, such as an Incidin Plus solution. Then wipe the cleaned areas so that they are dry.
- The only suitable cleaning method for the housing is wipe disinfection. If the disinfectant has a spray nozzle, apply disinfectant to a suitable cloth before using it on the device.

Work particularly carefully and cleanly with infectious material because the device cannot be decontaminated as a whole.

- Before using a cleaning or decontamination procedure other than that prescribed by the manufacturer, the user is required to check with the manufacturer that the intended procedure will not damage the device. Safety labels attached to the device must not have methanol applied.

2.4.7 Safety instructions – maintenance and repair

The device is generally maintained by the customer service department of Analytik Jena or specialist personnel trained and authorized by them.

Unauthorized maintenance can damage the device. For this reason, only the activities described in the user manual in the "Maintenance and care" chapter may be performed by the operator.

- Only clean the exterior of the device with a slightly moistened, non-dripping cloth. Use only water and, if required, customary surfactants.
- All maintenance and repair work on the device must only be carried out when the device is switched off (unless specified otherwise).

- The gas supply must be shut off before performing any maintenance or repair work (unless specified otherwise).
- Use only original spare parts, wear parts and consumables. They have been tested and ensure safe operation. Glass part are wear parts and are not subject to the warranty.
- All protective equipment must be reinstalled and checked for proper function when the maintenance or repair work is complete.

See also

 Maintenance and care [▶ 67]

2.5 Behavior during emergencies

- If there is no immediate risk of injury, switch off the device and the connected system components immediately in hazardous situations or in the event of an accident and/or disconnect the power plugs from the power outlets.
- Close the gas supply as soon as possible after switching off the devices.

3 Function and design

3.1 Layout

The analyzer is a compact laboratory device with permanently installed main components. Further accessories and reagents are required for the measurement process.

The control of the analyzer and the analysis of the measurement data is performed via the multiWin pro software installed on an external PC.

All components of the analyzer operated or serviced by the user can be reached via the two doors on the front.

The analyzer consists of the following main components:

- Sample supply system
- Gas box and hose system
- UV reactor with control gear
- Measuring gas drying and cleaning
- Detector
- Indicator and control elements, connections
- Electronics
- Accessories

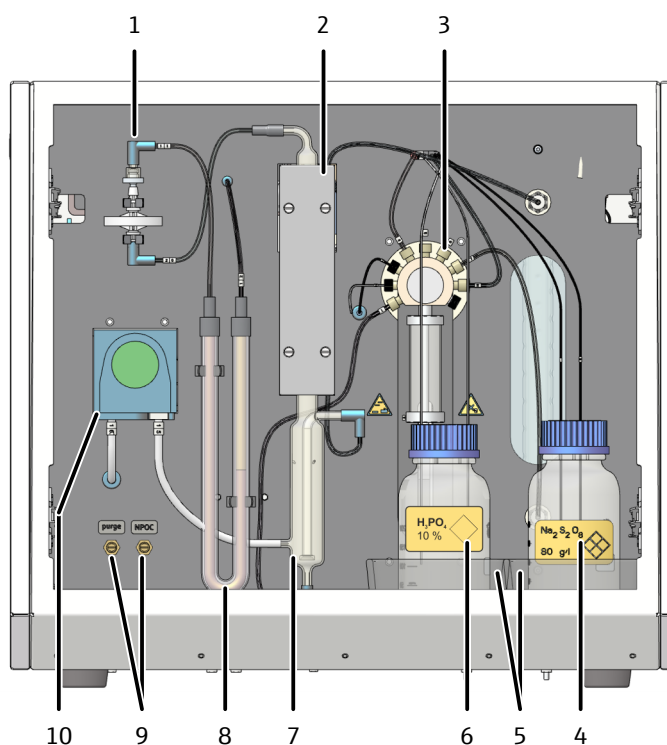

Fig. 1 Analyzer with open front

- | | |
|--|--|
| 1 Water traps | 2 Cooling block |
| 3 Syringe pump with 9-port valve | 4 Reagent bottle for $\text{Na}_2\text{S}_2\text{O}_8$ |
| 5 Drip trays | 6 Reagent bottle for H_3PO_4 |
| 7 TIC condensate container | 8 Halogen trap |
| 9 Needle valves to adjust the gas flow | 10 Condensate pump |

3.1.1 Sample supply system

Sample supply is carried out as flow injection via a syringe pump with 9-port valve. The injection volume is 50 to 20000 μl .

For small sample volumes ($V < 1.5 \text{ ml}$), system water is additionally added to the reactor with each dosage.

The hose connections are attached to the 9-port valve using Fingertight screw connections. The syringe body is made of glass and replaceable.

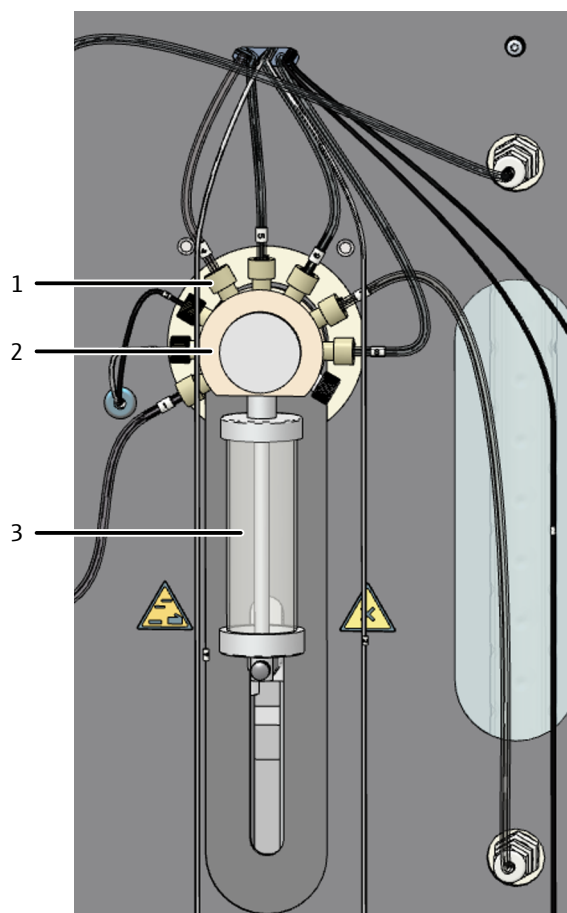

Fig. 2 Syringe pump

- | | |
|--------------------------|----------------|
| 1 Fingertight connection | 2 9-port valve |
| 3 Dosing syringe | |

The hoses on the 9-port valve are labeled and connected to the following components:

Hose	Connection to the component/accessory
1	TIC condensate container
2	Reagent bottle for phosphoric acid H_3PO_4
3	Reagent bottle for sodium persulfate $\text{Na}_2\text{S}_2\text{O}_8$
4	Waste disposal
5	Ultrapure water bottle
6	Sample
7	UV reactor
8	Waste disposal
9	Not used

3.1.2 Hose system

Hose diagram

The connection between the individual components is made with labeled hoses. The numbers and letters circled in the hose diagram correspond to the labels on the hoses in the analyzer.

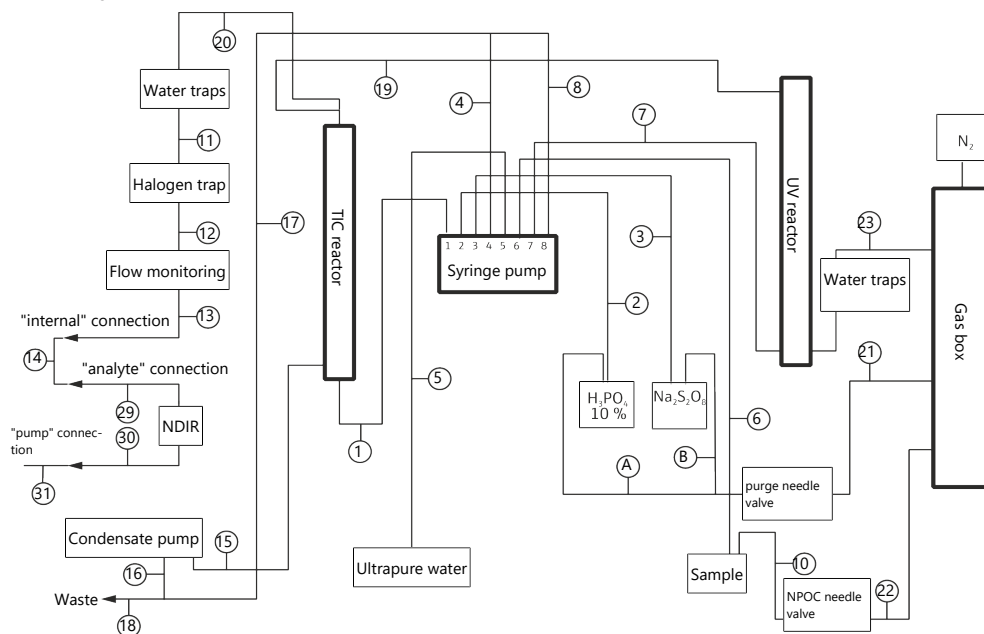

Fig. 3 Hose diagram

Connection method

Inside the device, most gas connections have been implemented via FAST connectors (FAST – Fast, Safe, Tight). These connectors provide a tight transition between the hoses and connections with different diameters. The soft sleeves prevent the risk of glass breakage in comparison to rigid screw connections. There are different connector versions.

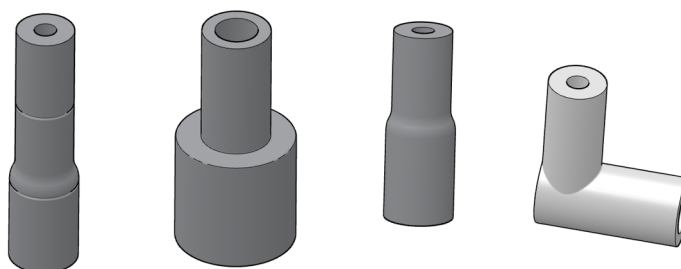

Fig. 4 FAST connector

So-called Fingertight screw connections are also used. These flangeless fittings consist of a conical nipple and a banjo bolt. These hose connections seal purely by tightening the plastic banjo bolt finger-tight.

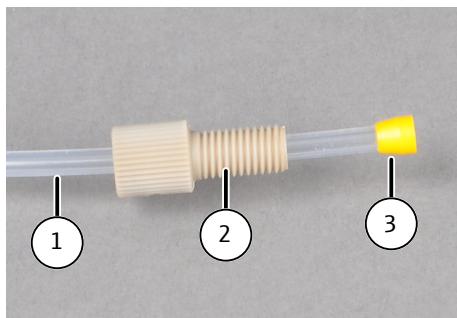

Fig. 5 Fingertight screw connection

- 1 Hose
- 2 Banjo bolt
- 3 Conical nipple

Components for flow adjustment

The analyzer automatically sets the carrier gas flow and controls the inlet flow via an MFC (Mass Flow Controller). An MFM (Mass Flow Meter) measures the carrier gas flow at the device outlet. This automatically checks for leaks. The results are displayed in the software in the **Instrument status** panel. A water trap protects the gas box from the return of wet combustion gases.

The NPOC purge flow and the purge flow for reagents can be set via the needle valve on the front side. The NPOC purge flow is measured with an MFM and displayed in the **Instrument status** panel.

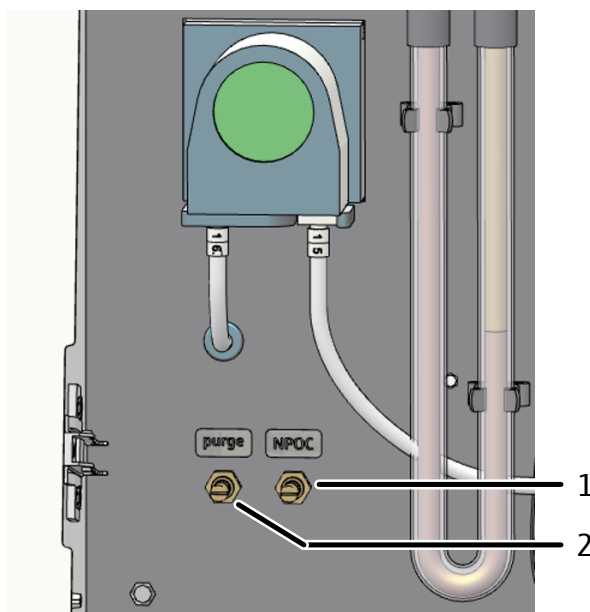

Fig. 6 Setting the NPOC purge flow and reagents purge flow

- 1 Needle valve for setting the NPOC purge flow (NPOC)
- 2 Needle valve for setting the reagents purge flow (purge)

Condensate pump

The condensate pump pumps the condensate or the waste solution from TIC determination out automatically after each measurement. The condensate pump is located behind the front doors next to the halogen trap.

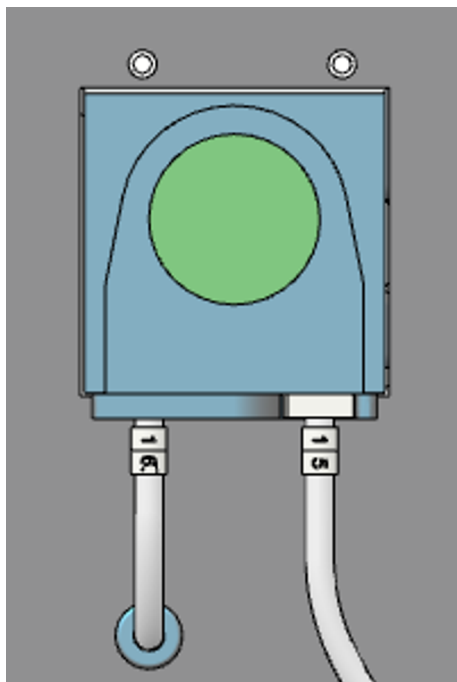

Fig. 7 Condensate pump

3.1.3 UV reactor with control gear

The analyzer features a specially developed UV reactor with an integrated UV radiation source made of quartz glass. The reactor directly surrounds the UV radiation source. Wavelengths 185 nm; 254 nm are used to oxidize samples. Thanks to its high radiation density, the UV radiation source digests the samples very well.

The UV reactor has two inlets and one outlet. The syringe pump feeds the sample and the reagent into the reactor via one inlet. The second inlet feeds in the carrier gas. The hose system transports the measuring gas further to the TIC condensate container via the top outlet.

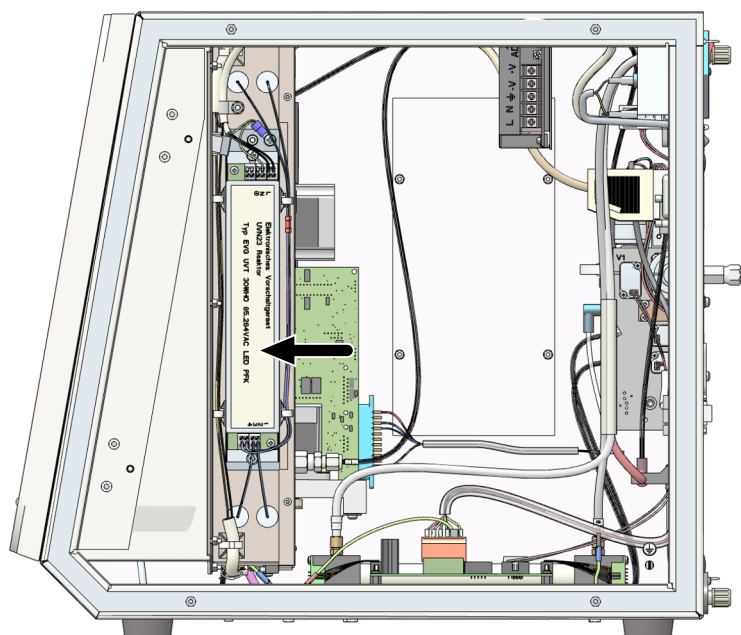

Fig. 8 UV reactor with control gear (right-hand side wall open)

3.1.4 Measuring gas drying and cleaning

TIC condensation module

The TIC condensation module consists of a TIC condensate container and a cooling block. The TIC reactor and the gas/liquid separator are combined in the TIC condensate container. The cooling block dries the measuring gas at the same time.

The TIC condensation module is located on the front side. The TIC condensate container has four connections. The right side connection connects the TIC condensate container with the UV reactor. The wet measuring gas/carrier gas mix is supplied via the connection. The gas is routed downward in the condensation module and exits via a glass drip. The integrated glass drip ensures the effective purging of the generated CO₂.

The cooling block dries the measuring gas by freezing out the water vapor. A Peltier element provides cooling. The dry measuring gas is routed out of the TIC condensate container via the top left connection. The measuring gas drying is maintenance-free.

The syringe pump routes the sample and reagents into the TIC condensate container before each measurement via the bottom connection and hose 1. The fourth connection is connected to the condensate pump. The condensate pump removes the waste from the TIC condensate container.

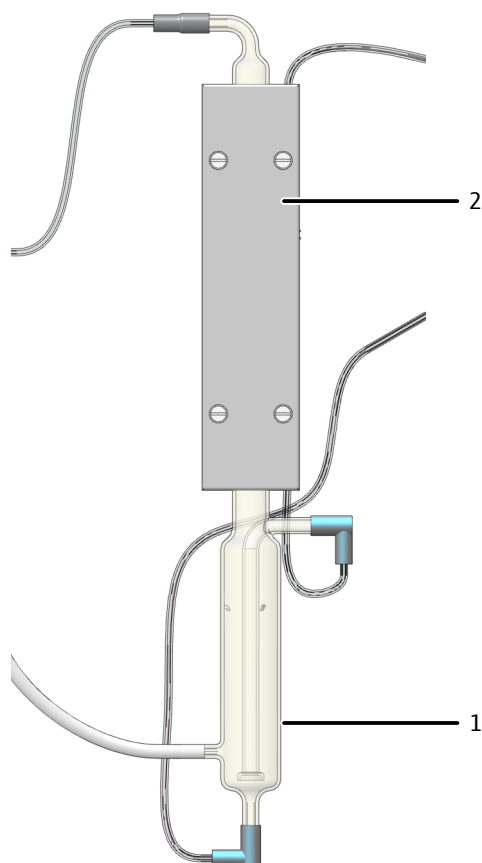

Fig. 9 TIC condensation module

1 TIC condensate container

2 Cooling block

Water traps

The water traps remove interfering components from the measuring gas and protect the detector and the gas box. The water traps are mounted in the gas path behind the cooling block or behind the gas box. The water traps each consist of a larger and a smaller water trap. The larger water trap (TC prefilter) retains aerosols during operation. The smaller water trap (disposable retention filter) retains rising water.

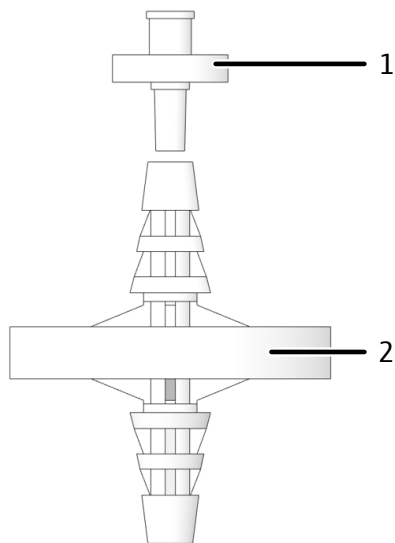

Fig. 10 Water traps

1 Disposable retention filter

2 TC prefilter

Halogen trap

The halogen trap removes interfering components (halogens, halogen-hydrogen compounds) from the measuring gas. It also protects the detectors and the flowmeter in this manner. The halogen trap is installed in the gas path behind the TIC condensate container and the water traps.

The halogen trap consists of a U-shaped tube. It is filled with special copper wool and brass wool. The filling of the halogen trap has to be replaced once half of the copper wool has changed color to black or when the brass wool has changed color at the latest.

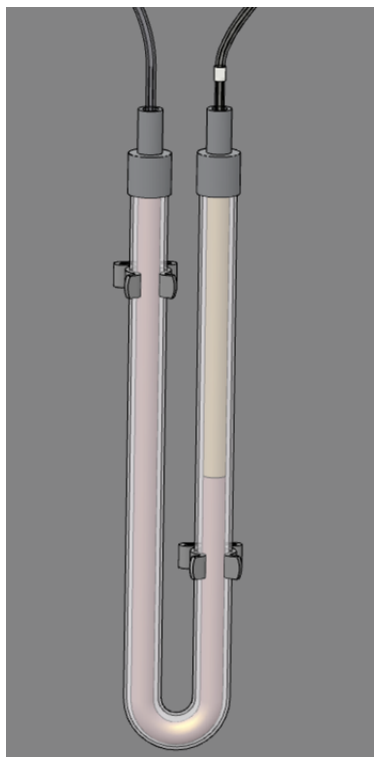

Fig. 11 Halogen trap

3.1.5 Detection

NDIR detector

The NDIR detector (non-dispersive infrared absorption detector) is behind the right side wall of the analyzer.

Gases with molecules from different atoms have specific absorption bands in the infrared wavelength range. When a light beam is sent through an arrangement of cells which contains IR-active gases, these gas components absorb a proportional share of the total radiation on their characteristic wavelengths according to their concentration in the gas mixture.

The radiation receiver used in the NDIR detector is selective for CO₂.

Measurements using the VITA method

The CO₂ molecules are detected metrologically as long as they remain in the cell of the NDIR detector. The measuring gas flow can fluctuate during CO₂ measurement, because, for example, liquid samples evaporate or condense during dosing. For this reason, the CO₂ molecules are sometimes detected spectrometrically for a longer time (at lower gas flows) or a shorter time (at higher gas flows).

The VITA method is formally the residence-time-coupled integration for TOC analyses. The measuring gas flow is determined in parallel with the NDIR signal in the VITA method. The NDIR signal is normalized via computer control. This compensates for occurring flow fluctuations, ensuring constant gas flow. Integration is only carried out after this.

A highly precise digital flowmeter detects the gas flow in the immediate area of the NDIR detector.

3.1.6 Indicator and control elements, connections

LED display

A green LED is installed on the left door of the analyzer. The LED is lit when the analyzer is switched on, indicating operational readiness.

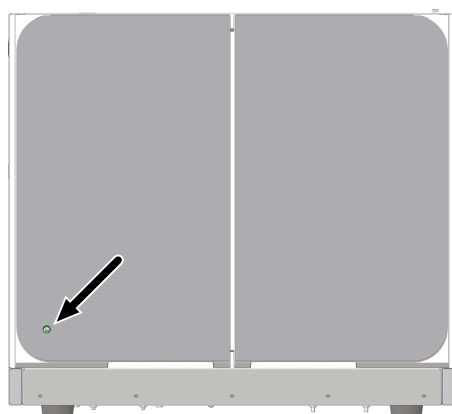

Fig. 12 Status LED

Main switch and connections

The main switch and the following connections are located on the rear of the analyzer:

- Mains power connection with device fuse
- Media connections for gases and waste
- Interfaces for PC and accessory connection

A diagram in the center details the different connections.

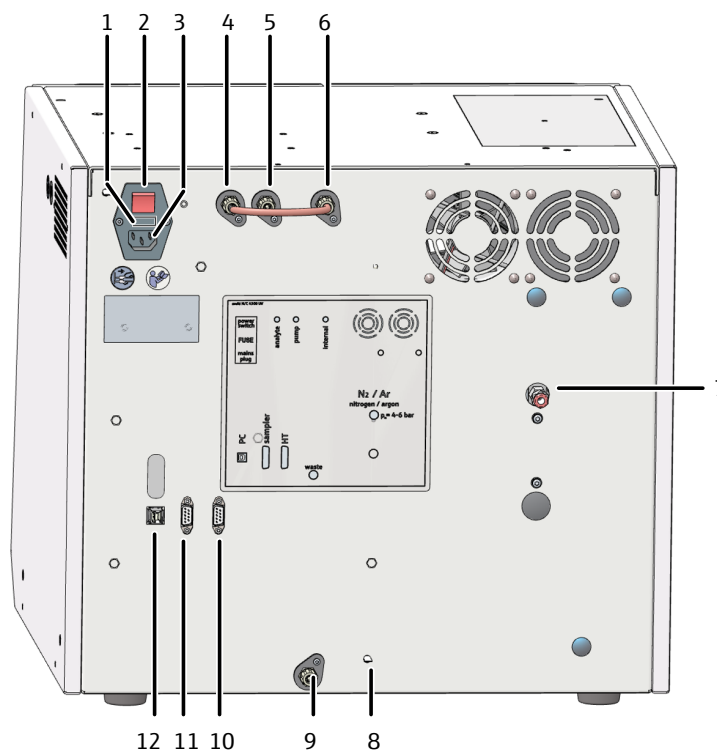

Fig. 13 Device rear

- | | |
|---|---|
| 1 "FUZE" mains fuse holder | 2 "Power switch" main switch |
| 3 "Main plug" mains connection | 4 "analyte" gas connection (connected to "internal" connection via hose bridge) |
| 5 "pump" gas connection | 6 "internal" gas connection |
| 7 "N ₂ " carrier gas connection | 8 Connection of the neutral conductor on the autosampler |
| 9 "waste" connection | 10 RS 232 interface to "HT" solids module |
| 11 RS 232 interface for "sampler" autosampler | 12 USB 2.0 "PC" interface |

Type plate

The type plate is attached to the device rear.

The type plate contains the following information:

- manufacturer address, trademark
- Designation of the device, serial number
- Electrical connection data
- Conformity markings
- WEEE marking

3.1.7 Reagents and accessories

The following reagents and accessories are required for measurements with the analyzer:

- Connection cables, connection hoses
- Suitable waste container or drainage
- Reagent bottle with drip tray for phosphoric acid (10 %)
- Reagent bottle with drip tray for sodium persulfate (Na₂S₂O₈) acidified with sulfuric acid for the digestion of carbon compounds to CO₂, (250 ml).
- Ultrapure water bottle (2.5 l)

The reagent bottles must be positioned in the drip trays behind the right-hand door.
The reagent bottles are labeled with safety symbols and the content name.

3.2 Additional options for the analyzer

Autosampler

The following autosamplers are available for the analyzer:

- AS vario with various tray sizes
- AS vario ER with various tray sizes and canula flushing
- AS 10e for 10 samples
- AS 21hp for 21 samples
- EPA Sampler with piercing function

External solids module

The addition of the external HT 1300 solids module to the analyzer enables the catalyst-free digestion of solid samples at temperatures of up to 1300 °C in the ceramic combustion furnace. The ceramic boats allow input of large sample sizes (up to 3000 mg). This can compensate for sample inhomogeneities.

Manual TIC solids module

The TIC determination in solid samples can be performed by equipping the analyzer with a TIC solids module. Large sample amounts can be weighed in an Erlenmeyer flask. The sample is acidified and magnetically stirred on a heating plate to digest carbonates and hydrogen carbonates to CO₂.

3.3 Function and measuring principle

The analyzer is a compact and powerful device for determining the total carbon content in aqueous samples.

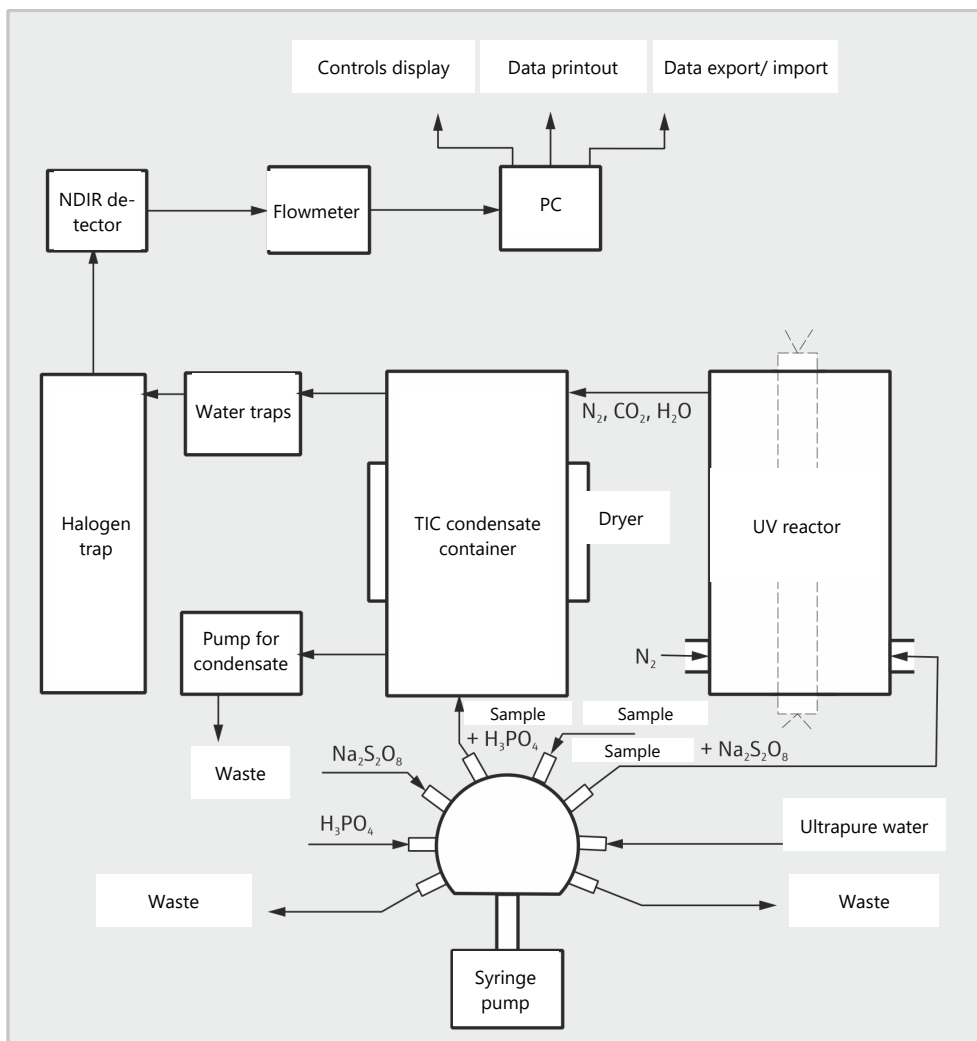

Fig. 14 Principle of operation

Digestion is carried wet-chemically via UV oxidation with or without the addition of the strong oxidant, sodium persulfate $\text{Na}_2\text{S}_2\text{O}_8$. Acidic persulfate solution is added to the sample aliquot in the UV reactor, and it is irradiated with wavelength 185 nm; 254 nm (UV-C) UV radiation. At temperatures of up to 80 °C, any carbon compounds contained are broken down into CO_2 . The digestion of the inorganic carbon takes place using phosphoric acid in the TIC reactor from an additional sample aliquot.



R-H - carbonic organic substance

The generated CO_2 is expelled using inert gas (N_2/Ar). After drying and removal of corrosive gases, the measuring gas is added to the NDIR detector.

The concentration of CO_2 is detected several times per second. An integral over time is calculated from this signal sequence. The integral is proportional to the concentration of the carbon in the measurement agent. Afterwards, the calculation of the carbon content in the sample is performed via a previously determined calibration function.

3.4 Measuring methods

The detection of several parameters can be combined in the control and analysis software.

3.4.1 TC analysis

TC: Total Carbon

In TC analysis, the total dissolved organic and inorganic bound carbon contained in the sample is detected. Elemental carbon and solids are not digested.

The sample is dosed automatically into the reactor and digested, and the carbon dioxide generated is detected.

3.4.2 TOC analysis

TOC: Total Organic Carbon

In TOC analysis, the total organic bound carbon contained in the sample is detected.

TOC determination is carried out in the analyzer using the differential method which can be described with the following formula.

$$\text{TOC} = \text{TC} - \text{TIC}$$

TOC - total organic carbon

TC - total carbon

TIC - total inorganic carbon

Two sequential measurements are used on one sample to determine TIC and TC. The calculated difference is given as TOC. The differential method detects volatile as well as non-volatile organic carbon compounds.

TOC analysis can be used when the sample contains easily purgeable organic substances such as benzol, cyclohexane, chloroform, etc. If the TIC content of the sample is significantly above the TOC content, TOC analysis should not be applied.

3.4.3 TIC analysis

TIC: Total Inorganic Carbon

In TIC analysis, the total inorganic carbon from carbonates and hydrocarbonates, as well as dissolved CO₂, is detected.

Cyanides, cyanates, isocyanates and carbon particles are not detected.

An aliquot of the sample is dosed directly into the TIC reactor to determine the inorganic carbon (TIC). The CO₂ is purged and detected.

3.4.4 NPOC analysis

NPOC: Non-purgeable Organic Carbon

During the NPOC analysis, the total non-purgeable organic carbon content of a sample is detected.

The sample is acidified to pH <2 with acid (H₂SO₄ (2 mol/l)). The guide value is 500 µl acid per 100 ml sample. The generated CO₂ is purged externally, e.g., in the autosampler. The analyzer then determines the remaining organic carbon in the sample.

Other highly volatile organic compounds are purged with the CO₂. The NPOC analysis should not be used when the sample contains easily purged organic substances.

NPOC analysis according to the NPOC plus method

This method was developed especially for the detection of low TOC content in samples with high TIC content or a high level of dissolved CO₂. The NPOC method is generally recommended for the analysis of such samples. For high and, in particular, unknown TIC content, very long time periods ($t > 10$ min) may, however, be required for complete purging of the CO₂. This is why the inorganic bound carbon is purged externally with this method.

The NPOC plus method process is a combination of the NPOC and the differential method.

- Acidify the sample outside the analyzer (pH <2).
- Purge most of the carbon dioxide formed externally immediately before analyzing.
- Prepare an NPOC plus method and analyze the samples.
- The analyzer determines the TC and TIC content of the prepared samples and calculates the NPOC content from the difference.

Since you have purged most of the inorganically bound carbon externally, the TIC value determined using this method is only a calculated value and has no analytical relevance.

Highly volatile organic substances are also purged during the sample preparation and not detected for this reason.

3.4.5 DOC analysis

DOC: Dissolved Organic Carbon

In DOC analysis, the organic carbon remaining in the filtrate after the sample is filtered is determined. The filter typically has a pore size of 0.45 μm.

The sample is filtered outside of the analyzer and then analyzed as a TOC sample.

3.4.6 Additional sum parameters

In the control and analysis software, you can activate the calculation of additional sum parameters in the method settings.

CSB

CSB (COD): Chemical Oxygen Demand

For TOC and NPOC methods, you can activate the calculation of the COD based on the TOC or NPOC.

Formula: $c(\text{COD}) = A \times c(\text{TOC}) + B$

You can define the rise (A) and intercept (B) for the calculation of the COD, default setting: A = 3.000, B = 0.000.

BOD₅

BOD₅: Biochemical Oxygen Demand

For TOC and NPOC methods, you can activate the calculation of the BOD₅ based on the TOC or NPOC.

Formula: $c(\text{BOD}_5) = A \times c(\text{TOC}) + B$

You can define the rise (A) and intercept (B) for the calculation of the BOD₅, default setting: A = 3.000, B = 0.000.

CO₂ For TIC methods and liquid measurements, you can activate the calculation of the carbon dioxide concentration based on the TIC.
Formula: $c(\text{CO}_2) = 2.833 \times c(\text{TIC})$

3.5 Calibration

3.5.1 Calibration strategies

Multiple point calibration with constant sample volume

In many applications, multiple point calibration with a constant dosage volume and multiple standard solutions at different concentrations is suitable.

The calibration range can encompass a wide range of concentrations and must be defined in accordance with the expected sample concentrations. Multiple standard solutions are measured with the selected method.

Multiple point calibration with constant concentration

Additionally, a multiple point calibration with variable dosage volumes and constant concentration can be performed. This calibration strategy is particularly interesting and the norm in the pharmaceutical industry for measurements at very low concentrations (<1 mg/l).

Only create one standard solution for the calibration range. The analyzer then analyzes different volumes of this standard solution. Do not go below the lowest standard solution volume of 1.6 ml when doing this.

Check the calibration via a second independently made standard solution to exclude errors during standard solution creation.

Take the blank value of the preparation water into account for measurements in the range of low concentration (<10 mg/l).

Single point calibration

For low TOC concentrations such as those in the pharmaceutical industry, single point calibration is a very good solution. A big advantage is that the device blank value is low and that the NDIR detector performs linear measurement across a wide range of concentrations.

Proceed as follows to minimize errors during manual standard solution creation:

- Prepare 3 standard solutions at the same concentration.
- Measure the standard solutions.
- Determine the calibration curve from the average value in the results.

Take the blank value of the preparation water into account during single point calibration.

3.5.2 Daily factor

Calibration with a standard solution can be checked and corrected via the daily factor. The software multiplies all subsequent measurement results with this factor.

The daily factor F is calculated in accordance with the following formula:

$$F = c_{\text{target}} / c_{\text{actual}}$$

3.5.3 Calibration method

Each parameter (TC, TOC, TIC, etc.) of a method can be calibrated in the software. Not all parameters require calibration, however.

You can define up to three linear calibration functions for different concentration ranges for each parameter. The software automatically assigns the measurement results to the correct calibration range.

The software determines the calibration function in relation to mass m per injected sample. It determines linear or quadratic calibration functions in accordance with the following equations via regressive calculation:

Linear calibration function: $c = (k_1 \times I_{\text{Net}} + k_0)/V$

Quadratic calibration function: $c = (k_2 \times I_{\text{Net}}^2 + k_1 \times I_{\text{Net}} + k_0)/V$

c : target concentration of the standards

V : Sample volume

I_{Net} : Net integral

k_0, k_1, k_2 : calibration coefficient

The net integral is the raw integral corrected by the blank value of the preparation water.

You can specify the regression type (linear or quadratic). Individual measuring points or measured values for the calculation of the current calibration (manual outlier selection) can be selected. If necessary, you can define individual standards again, or also add additional measurement points to the calibration.

TC/NPOC

The TC channel is calibrated directly for the TC parameter, and after sample purging for the NPOC parameter.

The concentration c_{TC} is proportional to integral I_{TC} : $c_{\text{TC}} = f(I_{\text{TC}})$.

TIC

The TIC channel is calibrated.

The following applies: $c_{\text{TIC}} = f(I_{\text{TIC}})$

TOC

The TOC is determined with the differential method (TOC Diff). Generally, separate calibration functions are determined for the TC and TIC channels.

The calculation of the analysis results is based on the calculated calibration functions for TC and TIC. The TOC content results from the following formula:

$$c_{\text{TOC}} = c_{\text{TC}} - c_{\text{TIC}}$$

The TC and TIC parameters can be calibrated simultaneously. The use of mixed standard solutions such as carbonate/hydrogen carbonate and potassium hydrogen phthalate or sucrose is recommended for this.

The TIC and TC channels can also be calibrated consecutively with separate standard solutions. This is useful if different ranges are to be calibrated for the TC and TIC channels.

NPOC plus

The calibration of the NPOC plus method is the same as the calibration of the TOC (Diff) method. Before analysis, the TIC must be sufficiently purged for the use of the differential method to be practical.

Method process:

- Separate calibration of TIC and TC channels
- Measurement of samples and calculation of the analysis results via the software
 - Purging of the acidified sample (3 to 5 min)
 - Determination of the remaining TIC with the calibration curve

- Determination of the TC with the calibration curve
- Calculation of the TOC from the difference of TC and TIC

The matrix-dependent calibration is as close to real samples as possible. To do this, add carbonate to the standard solutions until you get a TIC content similar to that of the samples.

3.5.4 Method characteristics

Coefficient of determination	The coefficient of determination allows the quality of fit of the regression model to be assessed. The coefficient of determination is calculated as the square of the correlation coefficient. The correlation coefficient compares the dispersion of the calibration measuring points of the regression function with the total dispersion of the calibration.
Limit of verification	The verification limit of the calibration specifies the lowest concentration that can be differentiated qualitatively from the zero point with a given probability. The verification limit should always be smaller than the lowest calibration measuring point.
Limit of determination	The determination limit of the calibration specifies the lowest concentration that can be differentiated quantitatively from the zero point with a given probability.

3.5.5 Other calculations

For all measurements where multiple injections are carried out, the average value (AV), the standard deviation (SD) and the variation coefficient (VC) are calculated and displayed. For each sample, a tenfold determination can be carried out as a maximum.

Outlier selection	<p>The control and analysis software can automatically select outliers. The user can specify a maximum limit for the variation coefficient or even for the standard deviation for this.</p> <p>The analyzer performs the minimum number of measurements specified in the method. If the distribution of the measured values is then above the specified maximum value (SD or VC), additional injections are carried out from the same sample until the specified maximum number of measurements has been reached.</p> <p>After each measurement, the software determines the variation coefficient and standard deviation for all combinations of the measured values. If the variation coefficient or the standard deviation of at least one combination is smaller than the specified maximum value, no further measurements are carried out.</p> <p>The software determines the analysis result from the combination of measured values with the smallest variation coefficient or the smallest standard deviation. The unused measurements are considered outliers and deleted.</p>
Average value	The average value of the final result is calculated from the concentrations determined for the individual detections after eliminating the outliers.

3.6 Blank values

3.6.1 Water blank values

Preparation water blank value	<p>Especially for measurements with low TOC concentrations ($\mu\text{g/l}$ range), the TOC content of the water used to prepare the standard solutions must be taken into account. The concentration of the standard solution and the TOC blank value of the preparation water are often within the same range. This blank value can be taken into account during calibration.</p> <p>The TOC content of the preparation water is measured separately before the calibration. The software then subtracts the average integral determined for the preparation water for each measuring point of the calibration from the determined gross integral.</p> $I_{\text{Net}} = I_{\text{Gross}} - I_{\text{Preparation water}}$ <p>The software determines the calibration function from the net integrals. Mathematically, this corresponds to a parallel movement of the calibration line.</p> <p>The software also takes the preparation water blank value into account when determining the daily factor.</p>
Diluent blank value	<p>If the sample is diluted, the blank value for the diluent is of interest. This value can be determined separately or entered manually in the software. The software takes the diluent blank value into account when calculating the concentration of diluted samples.</p> <p>The diluent blank value can change over time and must therefore be determined again before beginning a measurement series. Otherwise, the software will use the last value.</p> <p>The diluent blank value is always indicated in the software normalized to a volume of 1 ml.</p>
Diluent blank value use	<p>The software calculates the actual diluent integral (I_{DiBV}) for each measurement based on the diluent blank value, the sample volume used and the dilution ratio. The software then subtracts the diluent integral (I_{DiBV}) from the experimentally determined raw integral (I_{Raw}).</p> $I_{\text{DiBV}} = V_{\text{DiBV}} \times (V_{\text{Sample}} - N_{\text{p}}/N_{\text{D}} \times V_{\text{Sample}})$ $I_{\text{eff}} = I_{\text{Raw}} - I_{\text{DiBV}}$ <p>V_{DiBV}: Diluent blank value V_{Sample}: Sample volume I_{eff}: Effective integral N_{p}: Number of units of the primary sample N_{D}: Number of units of the diluent I_{Raw}: Raw integral I_{DiBV}: Diluent integral</p>
Diluent indication	<p>Proportions of the primary probe: in total proportions (e.g., 10 parts in 100 parts)</p> <p>This means that 10 ml of the primary sample is filled to a total volume of 100 ml with dilution water.</p> <p>A 1:1 dilution ratio equals $I_{\text{DiBV}} = 0$.</p>
Calculation of the sample concentration	<p>To calculate the sample concentration c, the sample volume and the dilution ratio are used:</p> $c = m/V_{\text{Sample}} \times N_{\text{D}}/N_{\text{P}}$

The following equation applies for the linear calibration function:

$$c = (k_1 \times I_{\text{eff}} + k_0) / V_{\text{Sample}} \times N_D / N_P$$

If the user dilutes a sample and enters the dilution ratio in the software, the software automatically calculates the concentration of the undiluted primary sample and outputs it to the analysis report.

3.6.2 Reagent blank value

Especially for the measurement of low TOC concentrations, the blank value (TIC/TC content) of the reagents used must be taken into account.

The following reagent blank values can be taken into account for all measurements:

- H_3PO_4 (TIC branch reagent): IC blank value
- $\text{Na}_2\text{S}_2\text{O}_8$ (TC branch reagent, i.e. for the UV reactor): TC blank value

The reagent blank value can be determined separately and entered manually in the software. Measuring the reagent blank value before a series of analyses and letting the software determine the blank value is recommended, however. The determined blank values (in area unit = FE) refer to the amount of reagent dosed.

It is good practice to always determine the reagent blank value again when the reagent is created. Otherwise, the software will use the last value.

The reagent blank values for the reagents used can be determined individually or as a group. For multiple determinations, separate determination provides the best results.

3.6.3 Eluate blank value

The eluate blank value is a special blank value for samples from cleaning validation or eluate preparation. It corresponds to the TOC content of the ultrapure water used which has been used, e.g., to extract/eluate swabs.

The eluate blank value is a fixed method parameter. The user can activate or deactivate the eluate blank value in the method. The user can optionally determine the eluate blank value separately and enter it in the software manually.

The blank value can change over time and must therefore be determined again before beginning a measurement series. Otherwise, the software uses the last value.

The eluate blank value is always indicated normalized to 1 ml.

The eluate blank value is not taken into account when carrying out a calibration. The calibration is carried out with normal standard solutions in which only the preparation water blank value is taken into account.

If samples are measured with the so-called eluate method, the software automatically subtracts the integral of the blank value from the integral of the sample measurement.

$$I_{\text{eff}} = I_{\text{Raw}} - I_{\text{Eluate blank value}}$$

I_{eff} : Effective integral

I_{Raw} : Raw integral

$I_{\text{Eluate blank value}}$: Eluate blank value

3.6.4 Boat blank value

For solids methods, the user can determine the boat blank value. To do this, the user inserts a boat with sample additives in the combustion furnace and analyzes it.

The user can optionally determine the boat blank value separately and enter it in the control and analysis software.

The boat blank value can change over time and must therefore be determined again before beginning a measurement series. Otherwise, the software will use the last value.

3.7 System suitability test

System suitability tests are used in the pharmaceuticals industry to validate analytical methods and devices to document the suitability of the selected procedure.

For TOC analysis in the ultrapure water range for pharmaceutical purposes, such as e.g., WFI (Water For Injection), the recovery rate of a poorly oxidizable compound is determined in comparison with that of an easily oxidizable compound.

The standards solutions and their concentrations are defined in the respective pharmacopeia, e.g., in the European Pharmacopeia or in the USP (United States Pharmacopeia). These define sucrose as an easily oxidizable compound, and p-benzoquinone as a poorly oxidizable one. The ratio of the recovery rate of p-benzoquinone to the recovery rate of sucrose must be within the range of 85 to 115 %. Only then is the selected method suitable.

Procedure:

- ▶ Create a reference solution of sucrose and TOC water with a concentration of 500 µg/l. This corresponds to a concentration of 1.19 mg/l sucrose.
- ▶ Prepare a solution of p-benzoquinone and TOC water that also has a concentration of 500 µg/l to check system suitability. This corresponds to a concentration of 0.75 mg/l p-benzoquinone.
- ▶ Determine the TOC concentrations of the reference solution, the system suitability solution and the TOC water in the selected mode (direct or differential method).

The effectiveness of the system in percent is calculated using the following formula:

$$E = (r_{ss} - r_w) / (r_s - r_w) \times 100$$

E: System efficiency in %

r_s : TOC of the reference solution (sucrose)

r_{ss} : TOC of the system suitability solution (p-benzoquinone)

r_w : TOC of the TOC water used (preparation water blank value)

4 Installation and commissioning

4.1 Installation conditions

4.1.1 Ambient conditions

- This laboratory device is designed for inside use.
- Avoid direct sunlight and radiation from heaters onto the device. If necessary, provide air conditioning.
- The installation site must be free of drafts, dust and caustic fumes. Dust and corrosive vapors can cause damage to the device, e.g., due to corrosion.
- The room air must be as low in TOC and NO_x as possible.
- Avoid mechanical shocks and vibrations.
- Do not locate the device near sources of electromagnetic interference.
- Place the device on an acid-resistant surface. If you are operating the device with an optional solids furnace, the table surface must also be heat-resistant.
- The device must be positioned in such a way that allows easy access from all sides.
- Keep the ventilation slits free and do not obstruct them with other devices.

The following climate requirements apply in the room of operation:

Operating temperature	+10 to 35 °C (air-conditioning recommended)
Maximum humidity	90 % at 30 °C
Air pressure	0.7 to 1.06 bar
Storage temperature	5 to 55 °C
Humidity during storage	10 to 30 % (use desiccant)
Operating altitude (max.)	2000 m

4.1.2 Device layout and space requirements

The basic device and its modules were designed as table-top devices. The required space depends on all components that make up the measuring station.

The AS 10e and AS 21hp liquid autosamplers are attached to the right side wall of the basic device. Alternatively, the autosamplers can be placed next to the device.

There must be a clearance of at least 10 cm between the device system and any cabinet/shelf located above it.

Further components of the measuring station:

- The PC, monitor and printer may be placed on a separate side table.
- An acid-resistant waste container can be placed on or under the bench.
- The AS vario, AS vario ER and EPA Sampler autosamplers must be positioned to the right of the basic device.
- The HT 1300 solids module and the manual TIC solids module are placed to the left of the basic device.

Component	Dimensions (Width x Depth x Height)	Weight
Basic device	513 x 547 x 464 mm	18 kg
AS 10e autosampler	260 x 320 x 390 mm	4.5 kg
AS 21hp autosampler	260 x 320 x 390 mm	4.5 kg

Component	Dimensions (Width x Depth x Height)	Weight
AS vario autosampler	350 x 400 x 470 mm	15 kg
AS vario ER autosampler (with canula flush)	350 x 400 x 470 mm	15 kg
EPA Sampler	500 x 540 x 550 mm	15 kg
HT 1300 solids module (with dust trap)	510 x 600 x 470 mm	22 kg
Manual TIC solids module	300 x 550 x 470 mm	10 kg

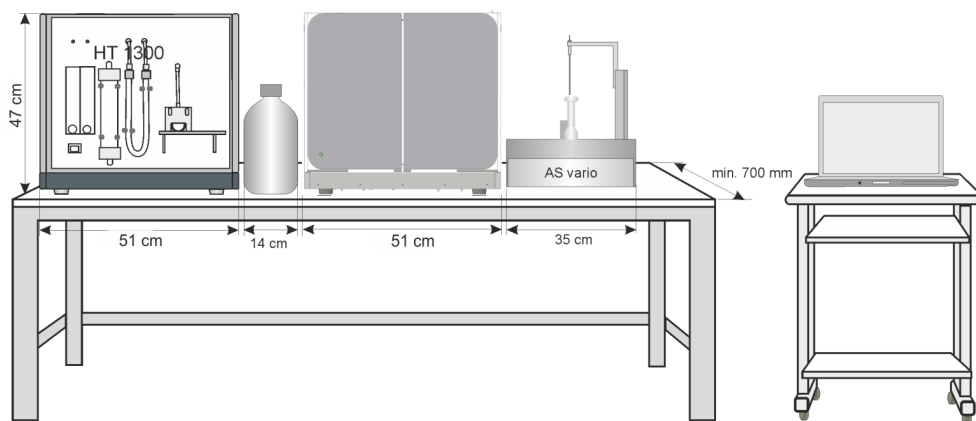

Fig. 15 Space required for multi N/C 4300 UV with modules

4.1.3 Power supply



WARNING

Danger due to electrical voltage

- Only connect the device to a properly grounded socket which complies with the voltage indicated on the device's rating plate.
- Do not use an adapter in the feeder.

The device operates on single-phase alternating current.

Before connecting the device to a power outlet, check its voltage rating to ensure that the required voltage and frequency match the available power source.

4.1.4 Gas supply

The operator is responsible for the gas supply with connections and pressure reducers.

The connection hose is supplied:

- Outer diameter 6 mm
- Inner diameter 4 mm

4.2 Unpacking and setting up the device

The device will be delivered directly to the final device location by a transportation company. The delivery by this company requires the presence of a person responsible for device installation.

It is imperative that all persons designated to operate the device are present during the briefing given by the service technician.

The device may only be set up, installed and repaired by the customer service department of Analytik Jena or by persons authorized by Analytik Jena.

When installing and commissioning your device, observe the information in the "Safety instructions" section. Compliance with these safety instructions is a requirement for the error-free installation and the proper functioning of your measuring station. Observe all warnings and instructions that are attached to the device itself or displayed by the control and analysis program.

To ensure trouble-free operation, please make sure that the installation conditions are observed.

4.2.1 Installing and commissioning the analyzer

After initial commissioning, you may want to transport the device again, or store it. You can recommission the analyzer as described below. Analytik Jena always recommends installation via customer service.

- ▶ Carefully remove the basic device, the accessories and the supplementary device from the transport packaging. Retain the transport packaging for future transport.
- ▶ Place the analyzer at its intended location.
- ▶ Remove the adhesive tape from the doors and side walls.
- ▶ Open the front doors.
- ▶ Install the halogen trap and the water traps.
- ▶ Mount the TIC condensate container on the front side.
- ▶ Connect the canulas with hoses 6 and 10. Tighten the Fingertight connections finger-tight.
- ▶ Put both reagent bottles with the drip tray in the analyzer.
- ▶ Close the doors of the analyzer.
 - ✓ The device has been installed.

See also

 Maintenance and care [▶ 67]

4.2.1.1 Connecting the analyzer

The mains power connection and the media connections are located on the rear of the device.

A diagram in the center details the different connections.

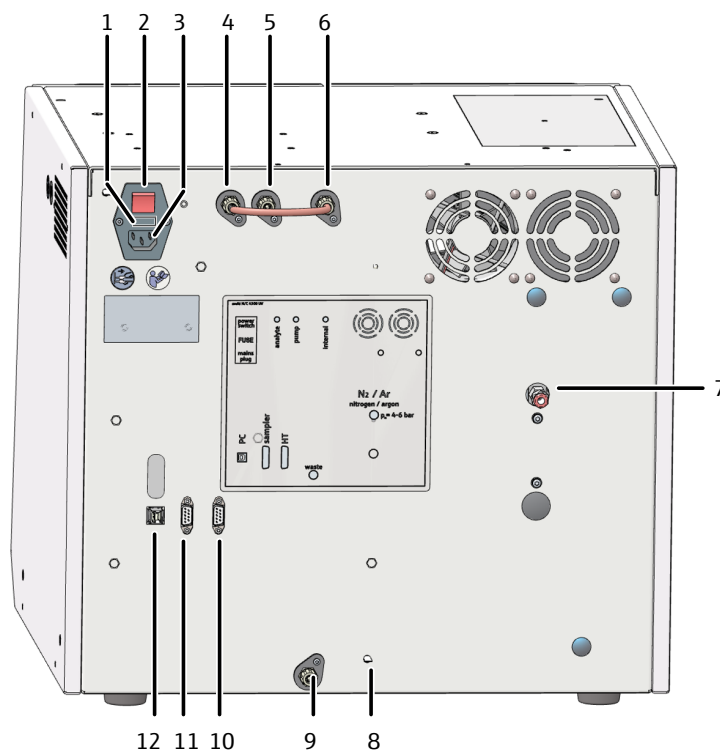

Fig. 16 Device rear

- | | |
|---|---|
| 1 "FUZE" mains fuse holder | 2 "Power switch" main switch |
| 3 "Main plug" mains connection | 4 "analyte" gas connection (connected to "internal" connection via hose bridge) |
| 5 "pump" gas connection | 6 "internal" gas connection |
| 7 "N ₂ " carrier gas connection | 8 Connection of the neutral conductor on the autosampler |
| 9 "waste" connection | 10 RS 232 interface to "HT" solids module |
| 11 RS 232 interface for "sampler" autosampler | 12 USB 2.0 "PC" interface |

Connecting the power



NOTE

Risk of damage to the sensitive electronics

- Only connect the device and the other components to the power grid when they are switched off.
- Only connect and disconnect electrical connection cables between the system components when the system is switched off.



NOTE

Damage to the electronics due to condensation

Significant temperature differences can lead to the formation of condensation which can damage the device's electronics.

- After long-term storage or transport in a colder environment, allow the device to acclimatize at room temperature for at least one hour before switching it on.

-
- ▶ Connect the connection cable to the mains power connection on the rear of the analyzer.
 - ▶ Connect the power plug to a grounded power outlet.
 - ▶ Do not switch the device on yet.

Connecting the gases

You are responsible for the gas supply in the laboratory. Ensure that the inlet pressure on the pressure reducer is set to 400 to 600 kPa.

- ▶ Connect the carrier gas. To do this, connect the supplied connection hose to the pressure reducer of the gas supply.
- ▶ Connect the carrier gas hose to the "N₂" gas connection on the rear of the device.
 - To do this, insert the hose in the quick-release connector.
 - To release the hose again later, press the red ring back and pull the hose out of the connection.

Connecting accessories



WARNING

Risk of chemical burns from concentrated acids

Concentrated acids are highly corrosive and sometimes have an oxidizing effect.

- Wear safety goggles and protective clothing when handling concentrated acids. Work under an extractor.
 - Observe all instructions and specifications in the safety data sheets.
-



CAUTION

Risk of poisoning from sodium persulfate

The strong oxidizing agent sodium peroxide is toxic when ingested. The salt irritates skin, eyes and respiratory pathways. Contact can cause allergic reactions, respiratory problems or asthma-like symptoms.

- Wear safety goggles and protective clothing when handling sodium persulfate. Work under an extractor.
 - Observe all instructions and specifications in the safety data sheet.
-

Connect the reagent bottles and accessory components as follows:

- ▶ Connect the waste hose to the "waste" connection on the rear of the analyzer. Put the free hose end in a suitable waste container.
- ▶ Open the front doors on the analyzer.

- ▶ Fill the reagent bottle with phosphoric acid (10 %). Put the bottle with the drip tray into the analyzer.
- ▶ Connect hoses 2 and A to the reagent bottle with phosphoric acid.
- ▶ Fill the reagent bottle with sodium persulfate solution. Put the bottle with the drip tray into the analyzer.
- ▶ Connect hoses 3 and B to the reagent bottle.
- ▶ Connect the following other hoses:
 - Ultrapure water 5 hose
 - Sample intake canula 6 hose
 - Sample purging canula: 10 hose
- ✓ The analyzer has been commissioned.

4.3 Connecting accessories



NOTE

Risk of damage to the sensitive electronics

- Only connect the device and the other components to the power grid when they are switched off.
 - Only connect and disconnect electrical connection cables between the system components when the system is switched off.
-

4.3.1 The AS 10e and AS 21hp autosamplers

AS 10e autosampler

The autosampler is equipped with a rotatable sample tray for 10 sample vessels with a volume of 50 ml. Optionally, sample values with a volume of 40 ml can be used.

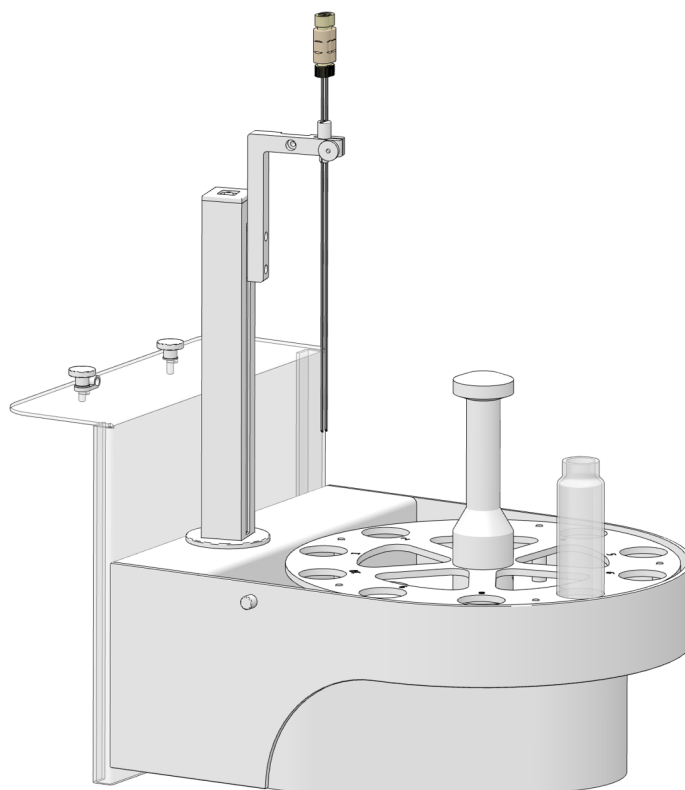

Fig. 17 AS 10e autosampler

The autosampler can be equipped with two canulas. This allows the autosampler to automatically purge samples for NPOC analysis.

During **NPOC analysis**, the sample is acidified outside the analyzer with diluted acid to a pH value <2 . The guide value is 500 μl acid per 100 ml sample. The autosampler purges volatile organic compounds and the produced CO_2 from the sample by means of the carrier gas. The analyzer then determines the remaining organic carbon.

During NPOC analysis, the autosampler works **sequentially**:

- First, the autosampler purges volatile organic compounds and CO_2 from the sample.
- In a second step, the autosampler picks up the prepared sample and transfers it via the intake hose to the analyzer.

AS 21hp autosampler

The autosampler is equipped with a rotatable sample tray for 21 sample vessels with a volume of 50 ml. Optionally, sample values with a volume of 40 ml can be used.

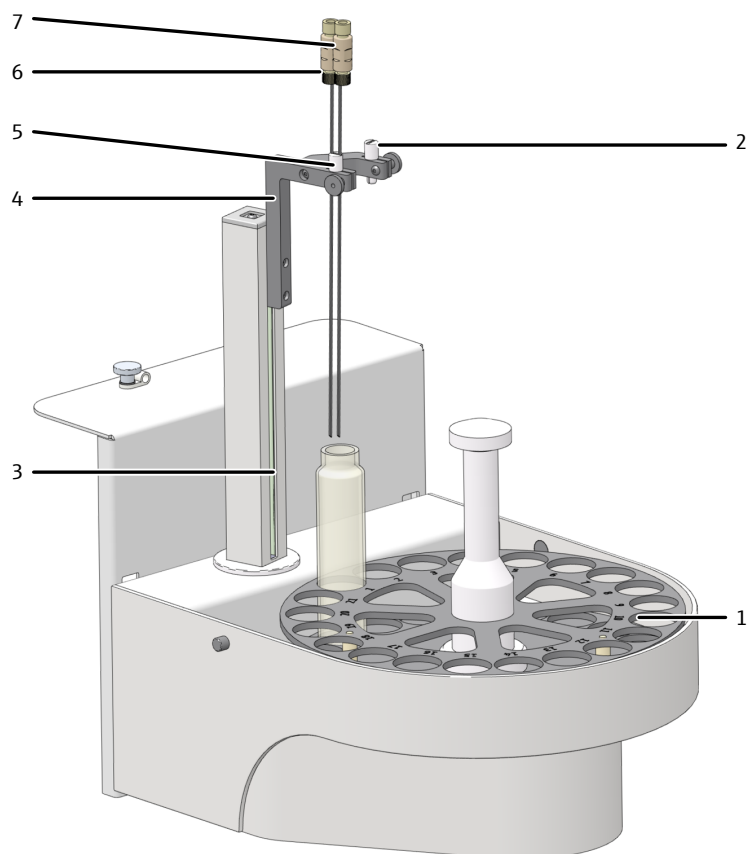

Fig. 18 AS 21hp autosampler

- | | |
|---|--|
| 1 Sleeve (with 1 bore) as a purging canula holder | 2 Sample tray (rotatable, 21 samples) |
| 3 Autosampler arm with Z-drive | 4 Cannula holder |
| 5 Sleeve (with 2 bores) | 6 Sample intake canula with screw connection |
| 7 Purging canula with screw connection | |

The autosampler can be equipped with two canulas. This allows the autosampler to automatically purge samples for NPOC analysis.

The autosampler comes with a canula holder for two canulas. The holder keeps the two canulas at a distance. This allows the autosampler to aspirate a sample and to purge a second sample in parallel (**parallel purging**). During NPOC analysis, the autosampler can also work sequentially (option).

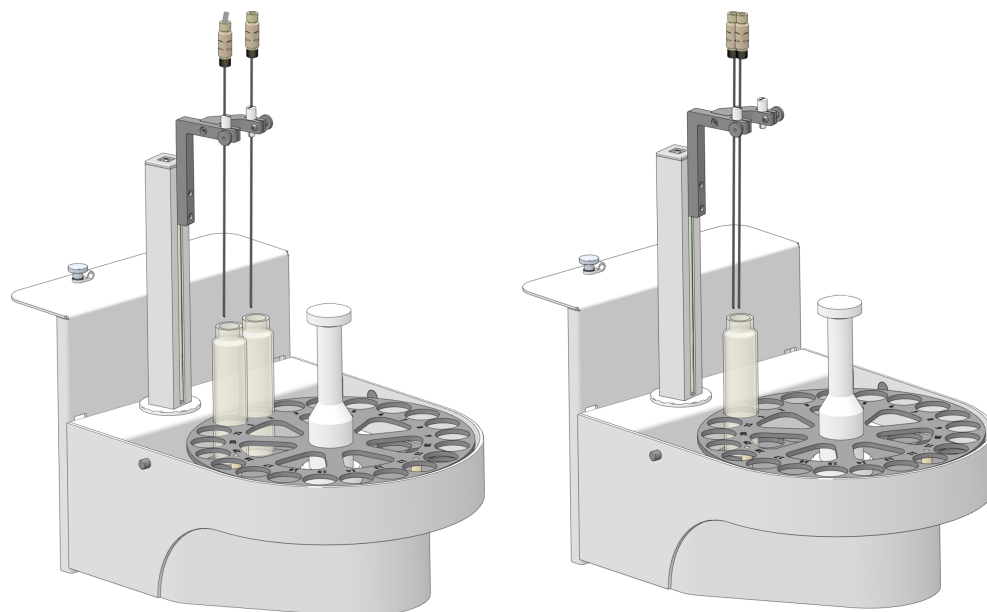

Fig. 19 Parallel purging (left) and sequential purging (right)

The autosampler has an integrated magnetic stirrer. The magnetic stirrer automatically homogenizes samples containing particles prior to sampling. You can define the stirring speed in the software in the method under the process parameters.

Autosampler in operation

Both autosamplers can be attached to the right-hand side of the analyzer by means of the supplied holder. Alternatively, the autosamplers can be placed next to the analyzer.

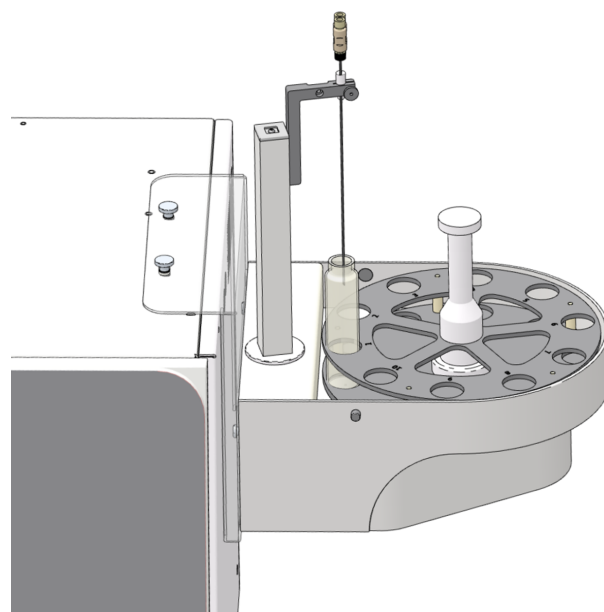

Fig. 20 Autosampler attached to the analyzer by means of the holder

The external power supply unit supplies the autosampler with operating voltage (24 V DC). The autosamplers do not have a mains switch. The analyzer is connected to the bottom of the autosampler via the RS 232 interface.

Cover (optional)

A cover is provided as an optional accessory for both autosamplers. The cover protects the sample chamber against environmental influences from the laboratory atmosphere.

4.3.1.1 Installing and commissioning the sampler



CAUTION

Risk of injury from moving parts

There is a risk of injury in the movement range of the sampler arm. For example, hands or fingers may be crushed. The canula can cause puncture injuries.

- Maintain a safety distance from the autosampler during operation.



NOTE

Risk of device damage

If the sampler arm is obstructed during operation, the drives can be destroyed.

- Do not touch the sampler arm during operation.
 - Only carry out manual adjustment when the device is switched off.
-
- ▶ Switch off the analyzer before installing the autosampler.
 - ▶ Plug the grounding conductor into the connection on the rear of the analyzer. Connect the grounding conductor to the connection on the bottom of the sampler.
 - ▶ Plug the cable on the low voltage side of the external power supply unit into the connection on the bottom of the sampler. Do not connect the power supply unit to the mains power supply yet.
 - ▶ Connect the autosampler to the analyzer with the interface cable (interface on the bottom of the sampler and "sampler" interface on the rear of the analyzer).



Fig. 21 Connections on the bottom of the autosampler

- | | |
|--|--------------------------|
| 1 Connection for equipotential bonding cable (grounding cable) | 2 Power cable connection |
| 3 Analyzer interface | |
- ▶ Attach the autosampler to the side of the analyzer with the holder.

- Screw the holder to the right side of the analyzer with the two knurled head screws.
- Insert the autosampler into the holder. To do this, insert the two knurled head screws on the rear of the sampler into the slots of the holder.

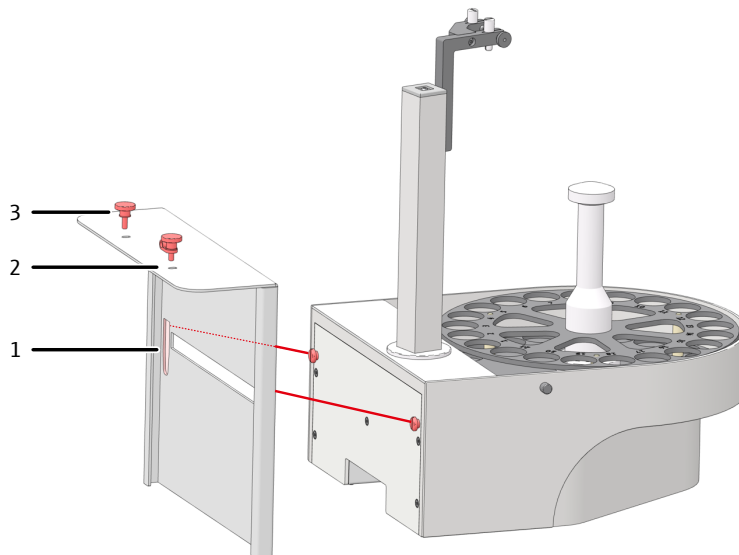

Fig. 22 Attaching the AS 21hp autosampler to the holder

- | | |
|--------------------------------------|-----------------------------------|
| 1 Slot for inserting the autosampler | 2 Bore for attaching the analyzer |
| 3 Knurled head screw | |

- ▶ **Alternatively:** Place the autosampler to the right of the analyzer.
- ▶ **Alternatively:** Place the autosampler to the left of the analyzer.
- ▶ Place the sample tray on the autosampler. Ensure that it clicks into place.
- ▶ Place a sample vessel in position 1 of the sample tray.
For AS 21hp autosamplers only: Place a magnetic stirring rod in the sample vessel.
- ▶ Insert the canulas in the canula holder. To do this, guide the two canulas through the sleeve with two holes (for sequential purging).
- ▶ Manually adjust the height of the canulas so that the canula tips protrude 1 to 2 cm over the edge of the vessel at the highest position of the autosampler arm and do not touch the vessels when the sample tray rotates.
- ▶ Secure the canulas by slightly tightening the knurled head screws.
- ▶ Connect the hoses from the analyzer to the canulas using Fingertight connections:
 - Hose 6 – sample intake hose
 - Hose 10 – purging hose for NPOC measurement
 - To do this, guide the hose through the banjo bolt (see image).
 - Slide the conical nipple onto the hose with the conical side towards the banjo bolt. The conical nipple and hose must be flush.
 - Retighten the Fingertight connections.

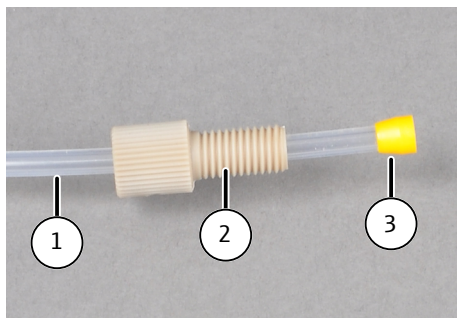

Fig. 23 Fingertight connection

- | | |
|------------------|--------------|
| 1 Hose | 2 Banjo bolt |
| 3 Conical nipple | |

Checking and extending the configuration

- ▶ Connect the power supply unit to the mains network.
- ▶ Switch on the components of the analysis system. Start the software.
- ▶ Check the device configuration with the **Instrument | Instruments** menu option in the **Instruments** window.
- ▶ If necessary, change the device configuration or create a new device configuration:
 - Click on the **Add** button to create a new device configuration.
 - Edit the device configuration in the detail view **Instrument configuration**.
 - Select autosampler in the dropdown menu under **Sampler type**.
 - Select Sample tray in the dropdown menu under **Rack size**.
- ▶ Select sample vial size from the dropdown menu **Vial size (mL)**:. The software adjusts the dead volume accordingly. Optionally you can adjust the dead volume at **Dead volume (mL)**:.
 - Click the button to save the device configuration.
 - Click on **Set default** to activate the device configuration as standard configuration.

Adjusting the autosampler

During adjustment, you adjust the immersion depth of the canulas so that the needles are optimally immersed in the sample vessels. Adjust the autosampler during commissioning and after each conversion, transportation or storage.

- ▶ Start the software
- ▶ Place the sample vessel in position 1.
- ▶ Place magnetic stirring rod in the sample vessel in the AS 21hp autosampler.
- ▶ Use the **Instrument | Sampler alignment** menu option to open the **Sampler alignment** window.
- ▶ Select adjustment position **Position 1** from the list box in the **Sampler position** section.
- ▶ Click on the **Request current values** button to retrieve the current offset values.
- ▶ Adjust the immersion depth of the canulas using the up-down control - **higher / + lower** in 0.1 mm steps.
- ▶ After each change, click **Move** to check the immersion depth.
- ▶ With the AS 21hp autosampler, maintain a distance of about 0.5 cm from the magnetic stirring rod so that the rod can move freely and does not damage the canulas.
- ▶ After adjustment save offset values by clicking on **Confirm**. Close the window.
 - ✓ The autosampler is ready for operation.

4.3.1.2 Conversion for parallel purging (AS 21hp)

The AS 21hp autosampler is equipped with a canula holder which can accommodate two canulas and keep them at a distance. By repositioning the canulas, the autosampler can be easily converted to "parallel purging".

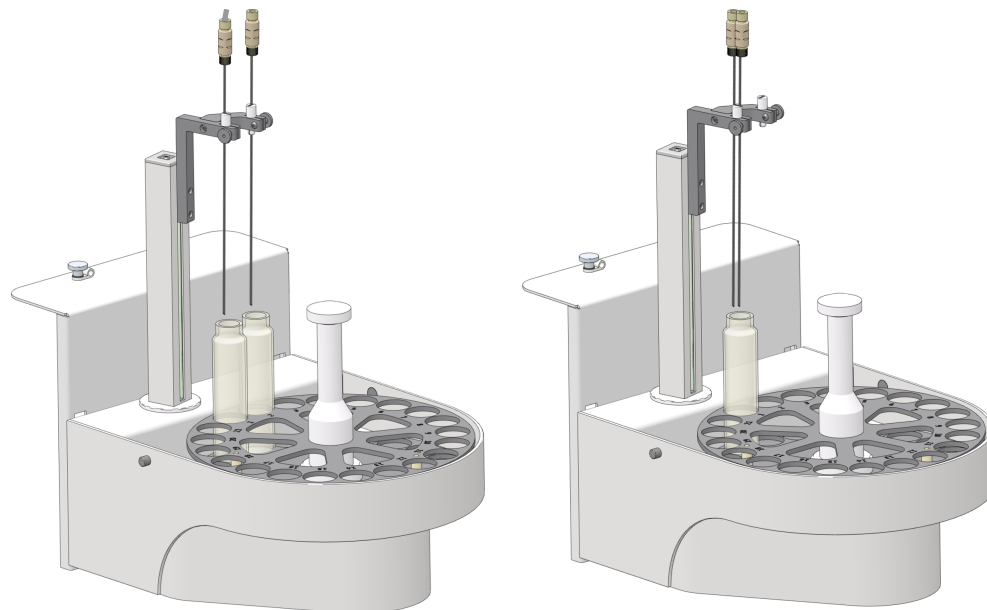

Fig. 24 Parallel purging (left) and sequential purging (right)

- ▶ Insert the canulas in the two positions of the canula holder in accordance with the image (left). Secure the canulas only slightly with the knurled head screws.
- ▶ Place two sample vessels in positions 1 and 2 of the sample tray under the two canulas.
- ▶ Place magnetic stirring rods in the vessels.
- ▶ Manually adjust the height of the canulas so that the canula tips protrude 1 to 2 cm over the edge of the vessel at the highest position of the autosampler arm and do not touch the vessels when the sample tray rotates.
- ▶ Secure the canulas by slightly tightening the knurled head screws.
- ▶ Connect the hoses to the canulas using Fingertight connections:
Sample intake hose 6 – connection to the canula above position 1
Purging hose for NPOC measurement 10 – connection to the canula above position 2
- ▶ Check the configuration and adjust the autosampler. Installing and commissioning the autosampler

See also

- 📖 Installing and commissioning the sampler [▶ 43]

4.3.2 AS vario autosampler



CAUTION

Risk of injury from moving parts

There is a risk of injury in the movement range of the sampler arm. For example, hands or fingers may be crushed. The canula can cause puncture injuries.

- Maintain a safety distance from the autosampler during operation.
-



NOTE

Risk of device damage by commissioning with transport locks

If you commission the device with the transport locks still in place, the drives may be damaged.

- Remove the transport locks before commissioning.
-



NOTE

Risk of device damage

If the sampler arm is obstructed during operation, the drives can be destroyed.

- Do not touch the sampler arm during operation.
 - Only carry out manual adjustment when the device is switched off.
-

5 different sample trays are available for the autosampler. A matching canula holder is available for each sample tray. The canula(s) can be flushed from the inside by drawing in sample or ultrapure water before sampling.

3 sample trays are available for the AS vario ER model.

The autosampler is placed next to the analyzer. It can be equipped with 2 canulas.

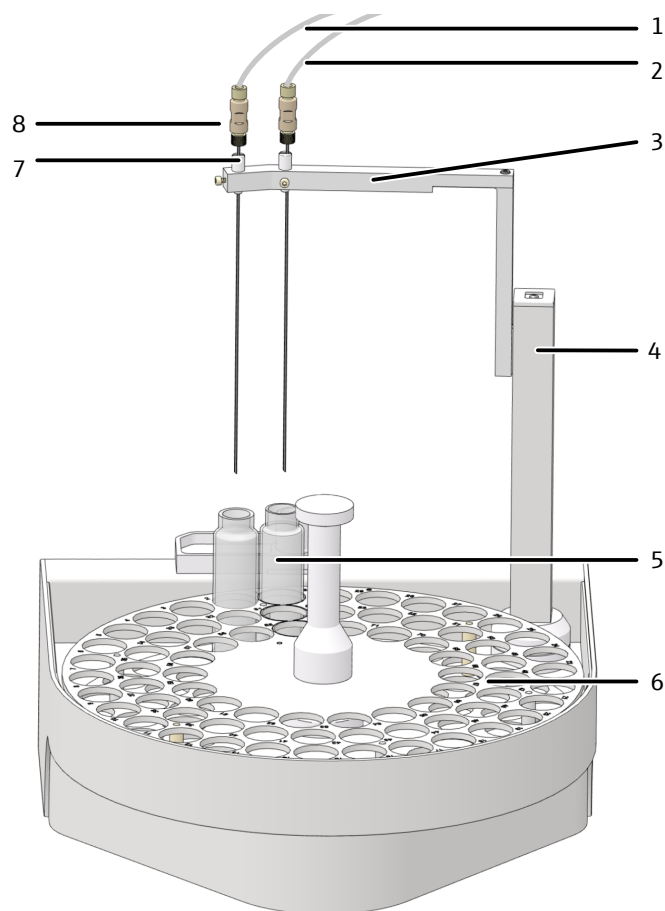

Fig. 25 Layout of the AS vario autosampler

- | | |
|---|--|
| 1 Connection hose to the analyzer (purging hose for NPOC measurement) | 2 Connection hose to the analyzer (sample intake hose) |
| 3 Canula holder | 4 Autosampler arm |
| 5 Sample vessel | 6 Sample tray |
| 7 Sleeve | 8 Canula |

The AS vario ER model is particularly suited for analyzing liquid samples with high solid particle content. The model is equipped with an additional canula flush that flushes the canula(s) with ultrapure water from the outside. When commissioning the autosampler, the ultrapure water supply for the canula flush must be installed additionally. It can be used for all measurement methods, and in particular for NPOC analysis with parallel purging. There is a suitable block with wash cups for each sample tray. When using different sample trays, simply unscrew the block with the wash cups from the autosampler and exchange it.

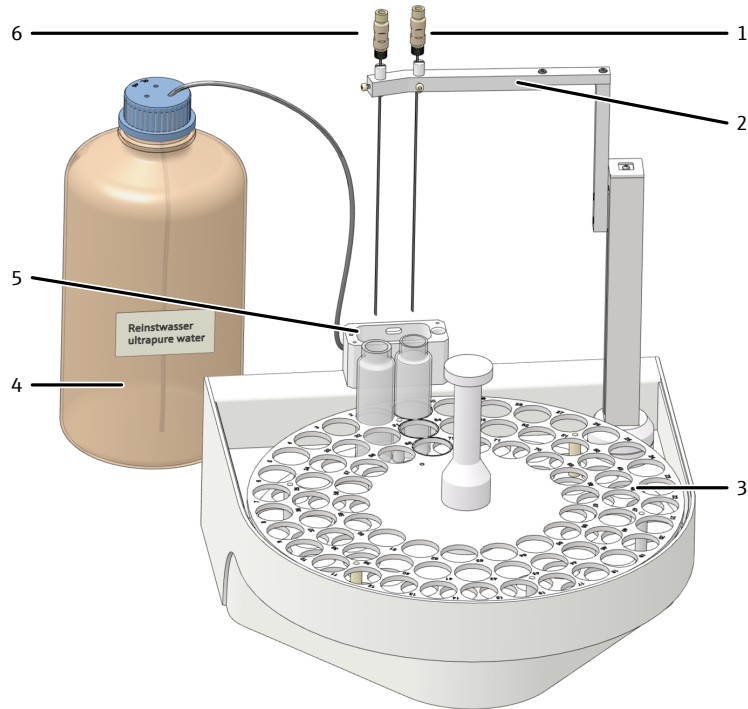

Fig. 26 Layout of the AS vario ER autosampler

- | | |
|---|--|
| 1 Canula for connection to the sample intake hose | 2 Canula holder (here with no. 72) |
| 3 Sample tray for 72 | 4 Ultrapure water bottle |
| 5 Canula flush | 6 Canula for connection with the purge hose for NPOC measurement |

Removing the transport locks

The autosampler is secured for transport with a retaining screw on the bottom of the autosampler. Retain the transport lock for later transport.

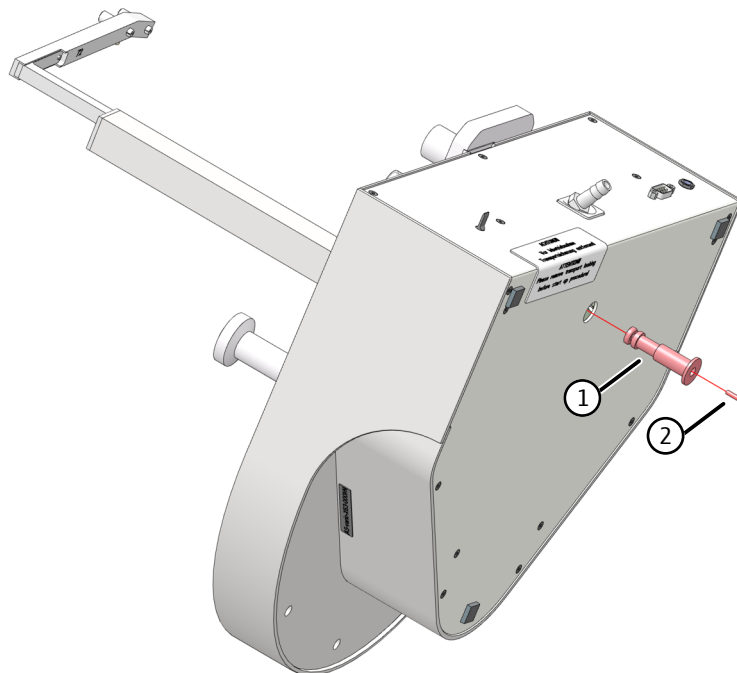

Fig. 27 Transport lock

- | | |
|------------------|---------------|
| 1 Transport lock | 2 M3x12 screw |
|------------------|---------------|

Commissioning the autosampler

- ▶ Turn the autosampler on its side and put it down safely.
- ▶ Remove the screw with the supplied hexagon socket screwdriver. Remove the transport lock (red plastic part).
- ▶ Place the autosampler on the bottom plate again.
- ▶ Switch off the analyzer before installing the autosampler.
- ▶ Plug the grounding conductor into the connection on the rear of the analyzer. Connect the grounding conductor to the connection on the rear of the autosampler.
- ▶ Plug the cable on the low voltage side of the external power supply unit into the connection on the rear of the autosampler. Do not connect the power supply unit to the mains power supply yet.
- ▶ Connect the autosampler to the analyzer with the interface cable (interface on the bottom of the sampler and "sampler" interface on the rear of the analyzer).
- ▶ Attach the outlet hose to the outlet connection on the rear of the autosampler. Insert the other end of the hose into the opening in the cover of the waste bottle.
 - i** NOTE! Route the outlet tube at a constant downward incline. If necessary, shorten the hose. The hose must not dip into the liquid.
- ▶ Place the sample tray on the autosampler. Ensure that it clicks into place.
- ▶ Check that the correct canula holder is installed on the autosampler arm. The number engraved on the bottom must match the maximum number of sample vessels on the sample tray for this.
- ▶ Insert the canulas with matching sleeves into the canula holders.
- ▶ For NPOC measurement with parallel purging: Insert one canula each with sleeve in both positions of the canula holder (Fig. 25  48).
- ▶ For NPOC measurement with non-parallel purging: Insert both canulas in one sleeve with two holes in the position on the right (see below, not suitable for AS vario ER).



Fig. 28 Sleeve with two canulas for non-parallel purging

- ▶ Manually adjust the height of the canulas so that the canula tips protrude 1 to 2 cm over the edge of the vessel at the highest position of the autosampler arm and do not touch the vessels when the sample tray rotates.
- ▶ Secure the canulas by slightly tightening the knurled head screws.
- ▶ Connect the hoses from the analyzer to the canulas using Fingertight connections:
 - Hose 6 – sample intake hose
 - Hose 10 – purging hose for NPOC measurement
 - To do this, guide the hose through the banjo bolt (see image).
 - Slide the conical nipple onto the hose with the conical side towards the banjo bolt. The conical nipple and hose must be flush.
 - Retighten the Fingertight connections.

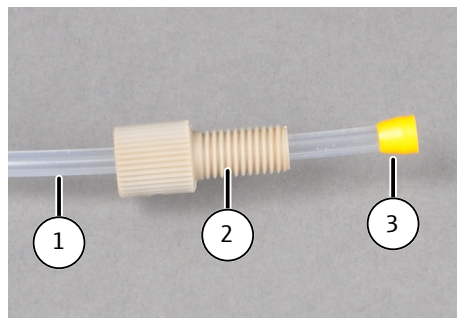

Fig. 29 Fingertight connection

- | | |
|------------------|--------------|
| 1 Hose | 2 Banjo bolt |
| 3 Conical nipple | |

Checking and extending the configuration

- ▶ Connect the power supply unit to the mains network.
- ▶ Switch on the components of the analysis system. Start the software.
- ▶ Check the device configuration with the **Instrument | Instruments** menu option in the **Instruments** window.
- ▶ If necessary, change the device configuration or create a new device configuration:
 - Click on the **Add** button to create a new device configuration.
 - Edit the device configuration in the detail view **Instrument configuration**.
 - Select autosampler in the dropdown menu under **Sampler type**.
 - Select Sample tray in the dropdown menu under **Rack size**.
- ▶ Select sample vial size from the dropdown menu **Vial size (mL)**. The software adjusts the dead volume accordingly. Optionally you can adjust the dead volume at **Dead volume (mL)**.
- ▶ Click the button to save the device configuration.
- ▶ Click on **Set default** to activate the device configuration as standard configuration.

Installing the canula flush

There is a suitable canula holder and a block with wash cups for each sample tray. The tray, the canula holder and the block are marked with the maximum sample number, e.g., 72.

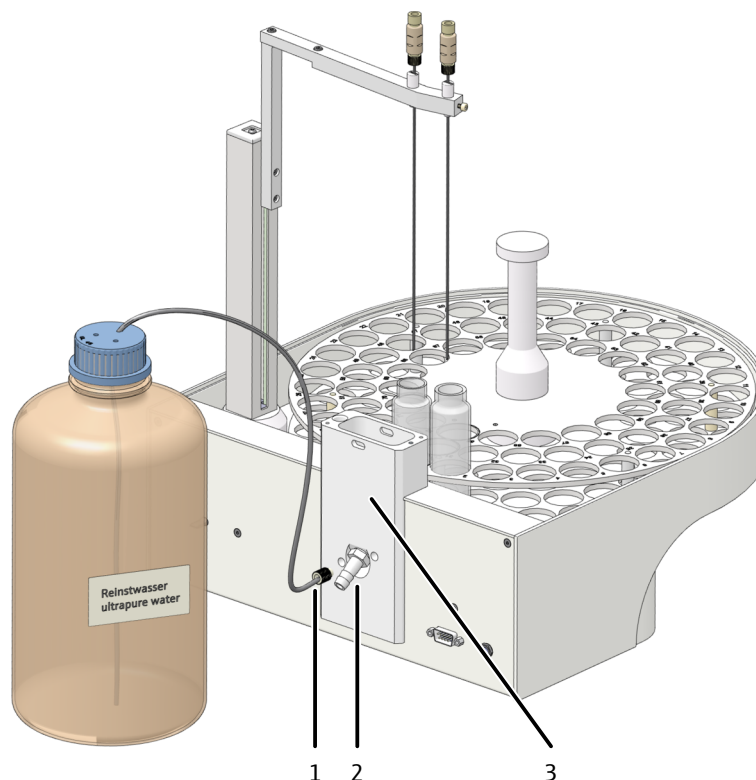

Fig. 30 Canula flush on the AS vario ER model

- 1 Ultrapure water connection 2 Waste connection
3 Removable block with wash cups

- ▶ Place the suitable block with wash cups on the autosampler.
 - For simpler installation, wet the O-ring on the bottom of the block with water.
 - Fasten the block to the autosampler with the two hexagon socket screws.
- ▶ Screw the ultrapure water connection into connection (1) and place the hose end in the ultrapure water bottle.
- ▶ Insert the waste hose in connection (2). Place the hose end in the waste container.
 - i** NOTE! Route the outlet tube at a constant downward incline. If necessary, shorten the hose. The hose must not dip into the liquid.
- ▶ Adjust the autosampler before the first start.

Activating the canula flush for measurements

- ▶ Create a new method.
- ▶ Set the number of flushing cycles on the **Step properties** tab at **Reverse rinse**. One flushing process is usually sufficient.

See also

- 📖 Adjusting the AS vario autosampler [▶ 68]

4.3.3 EPA Sampler



CAUTION

Risk of injury from moving parts

There is a risk of injury in the movement range of the sampler arm. For example, hands or fingers may be crushed. The canula can cause puncture injuries.

- Maintain a safety distance from the autosampler during operation.



NOTE

Risk of device damage

If the sampler arm is obstructed during operation, the drives can be destroyed.

- Do not touch the sampler arm during operation.
- Only carry out manual adjustment when the device is switched off.

The autosampler has a piercing function for sample vessels with septum caps. The sampler can be equipped with 1 to 2 canulas.

Design

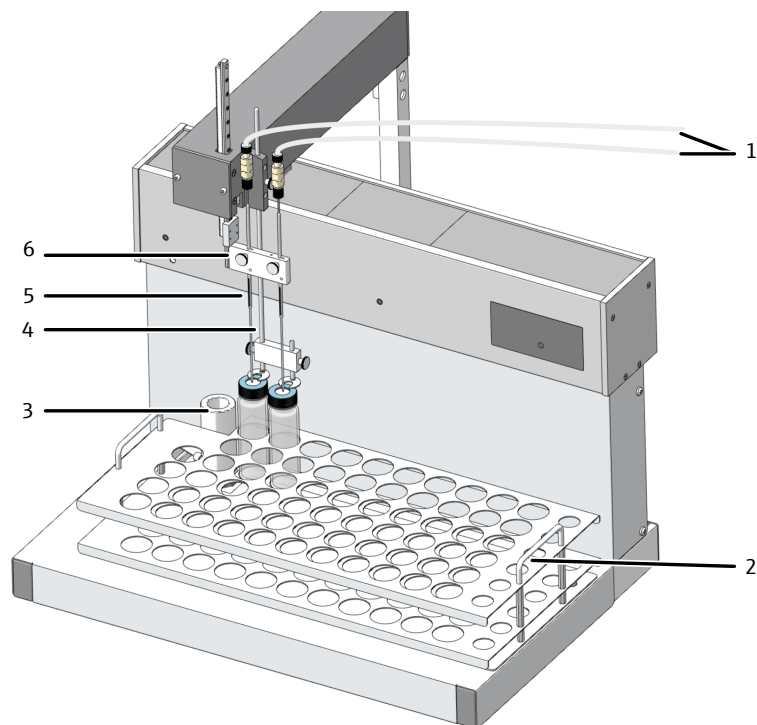

Fig. 31 EPA Sampler autosampler

- | | |
|------------------------------------|--------------------------------------|
| 1 Connection hoses to the analyzer | 2 Sample tray |
| 3 Wash cup | 4 Holding-down clamp |
| 5 Special canula | 6 Autosampler arm with canula holder |

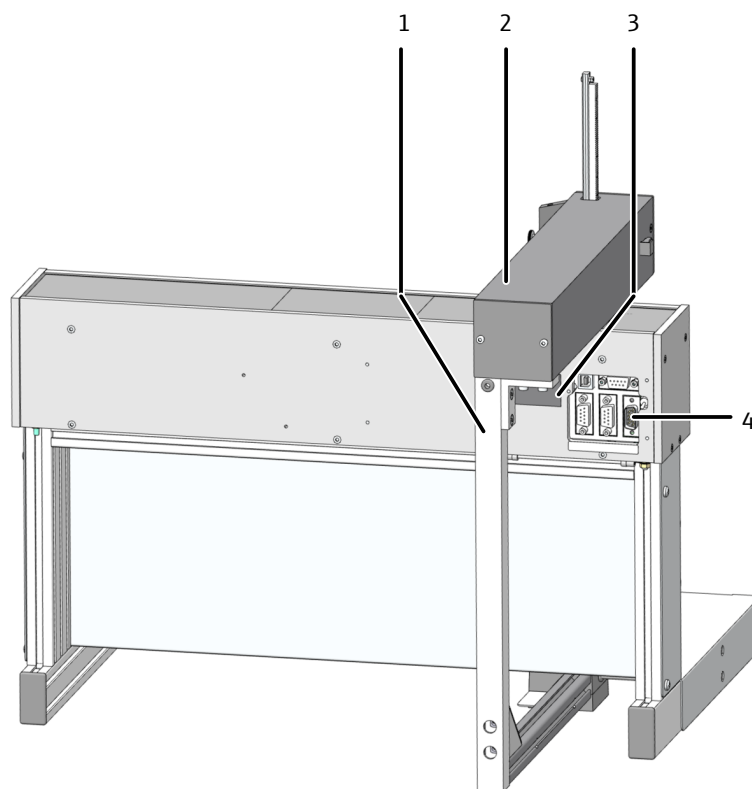

Fig. 32 Rear of the autosampler

- | | |
|---------------|--------------------------|
| 1 Stirrer arm | 2 Autosampler arm |
| 3 Type plate | 4 Electrical connections |

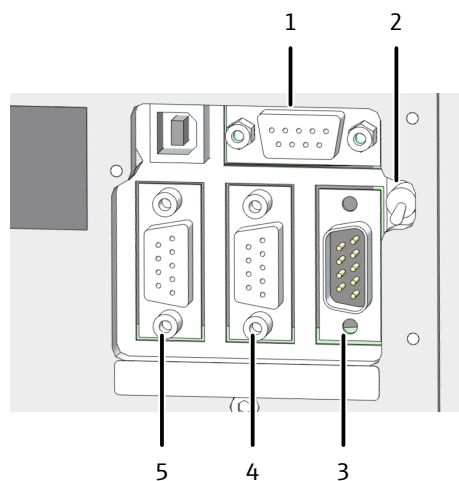

Fig. 33 Electrical connections

- | | |
|--------------------------------|-----------------|
| 1 Power supply unit connection | 2 Device switch |
| 3 Connection to the analyzer | 4 Not used |
| 5 Stirrer connection | |

Commissioning the autosampler

- ▶ Remove the transport lock:
 - Remove the two countersunk screws with the A/F3 hexagon head wrench supplied.
 - Remove the complete transport retaining clip and retain it for later transport.

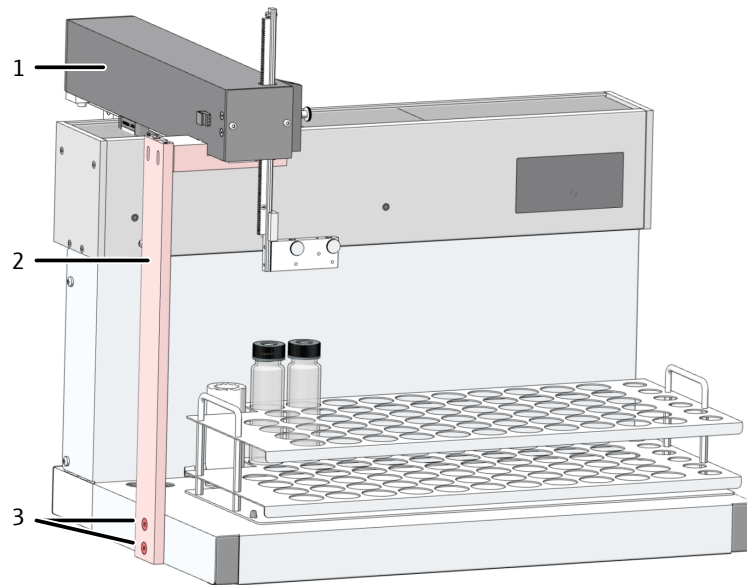

Fig. 34 Transport lock

- 1 Autosampler arm
- 2 Transport retaining clip
- 3 Screws

- ▶ Install the stirring arm:
 - Install the stirring arm on the bracket on the rear of the autosampler arm.
- ▶ Screw on the arm with the supplied countersunk screws (M4x10) using the hexagon head wrench (A/F2.5).
 - Tighten the screws evenly to aligned the arm.
 - Connect the stirrer cable to the "Stirrer" connection on the rear of the autosampler.

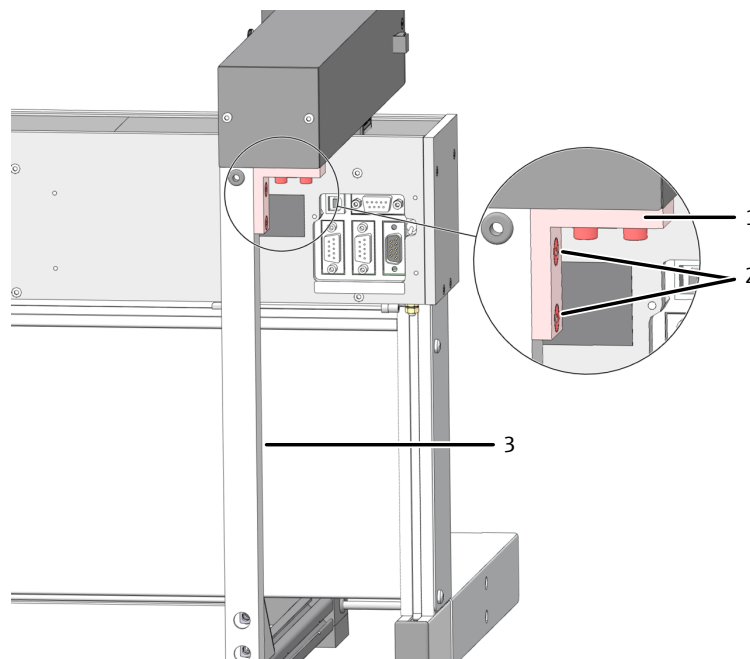

Fig. 35 Installing the stirring arm

- 1 Bracket on the autosampler arm
- 2 Countersunk screws
- 3 Stirrer arm

- ▶ Place the autosampler next to the analyzer. Position the autosampler so that enough space is provided behind the device for the motion range of the autosampler arm as well.
- ▶ Connect the low voltage side cable of the table power supply unit to the rear of the autosampler. Do not connect the power supply unit to the mains power supply yet.
- ▶ Connect the supplied serial data cable to the "sampler" interface on the rear of the analyzer. Connect the other end of the data cable to the interface on the autosampler.
- ▶ Plug the grounding conductor into the connection on the rear of the analyzer.
- ▶ Connect the waste hose to the wash cup of the autosampler and to a suitable waste container or drain.
 - i** NOTE! Route the outlet hose at a constant downward incline. If necessary, shorten the hose. The hose must not dip into the liquid.
- ▶ Install the wash cup on the autosampler.
- ▶ Place the sample tray onto the space provided.
- ▶ Note the positioning of the tray. The label must be legible when facing the front of the device. The two black centering pins on the contact surface of the autosampler protrude into the drill holes on the bottom of the tray.
- ▶ Insert the piercing canulas and holding-down clamps into the autosampler arm.
- ▶ Clamp the two canulas high enough in the holder to prevent them dipping into the vessels (basic position).

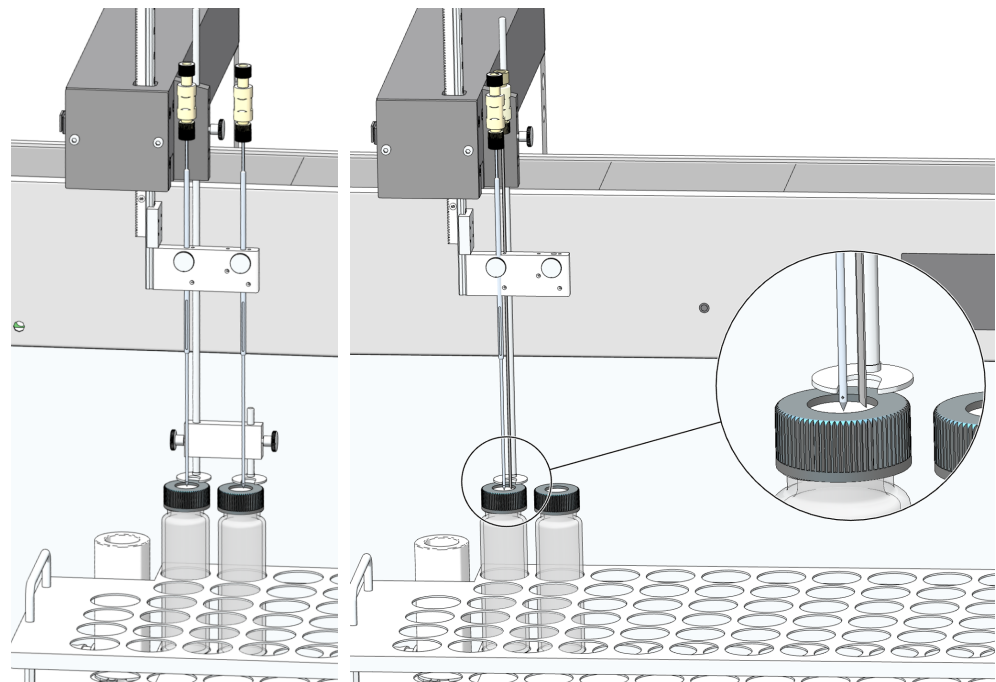

Fig. 36 Canula position for NPOC measurement with parallel (left) and non-parallel (right) purging.

- ▶ Secure the canulas by slightly tightening the knurled head screws.
- ▶ Connect the hoses from the analyzer to the canulas using Fingertight connections:
 - Hose 6 – sample intake hose
 - Hose 10 – purging hose for NPOC measurement
 - To do this, guide the hose through the banjo bolt (see image).
 - Slide the conical nipple onto the hose with the conical side towards the banjo bolt. The conical nipple and hose must be flush.

- Retighten the Fingertight connections.

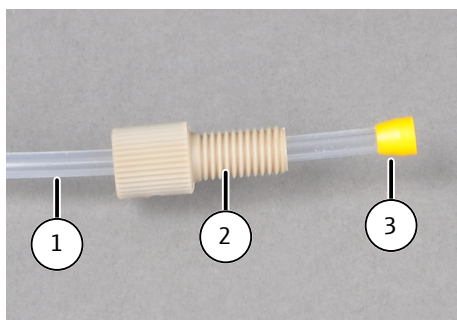

Fig. 37 Fingertight connection

- 1 Hose
- 2 Banjo bolt
- 3 Conical nipple

Checking and extending the configuration

- ▶ Connect the power supply unit to the mains network. Switch on the autosampler.
- ▶ Switch on the components of the analysis system. Start the software.
- ▶ Check the device configuration with the **Instrument | Instruments** menu option in the **Instruments** window.
- ▶ If necessary, change the device configuration or create a new device configuration:
 - Click on the **Add** button to create a new device configuration.
 - Edit the device configuration in the detail view **Instrument configuration**.
 - Select autosampler in the dropdown menu under **Sampler type**.
 - Select Sample tray in the dropdown menu under **Rack size**.
- ▶ Select sample vial size from the dropdown menu **Vial size (mL)**. The software adjusts the dead volume accordingly. Optionally you can adjust the dead volume at **Dead volume (mL)**.
- ▶ Click the button to save the device configuration.
- ▶ Click on **Set default** to activate the device configuration as standard configuration.
- ▶ Adjust the autosampler before the first start.

See also

- 📖 Adjusting the EPA Sampler [▶ 70]

4.3.4 External solids module



NOTE

Observe accessory instructions

This accessory has separate instructions containing important information and measures for hazard prevention.

- Observe the separate instructions for the accessory during installation.

Connection to the analyzer

- ▶ Set up the solids module next to the analyzer.
- ▶ Connect the "analyte" connection on the solids module to the "analyte" connection on the rear of the analyzer.

- ▶ Connect the "pump" connection on the solids module to the "pump" connection on the rear of the analyzer.
- ▶ Connect the connection hose for oxygen to the gas supply pressure reducer and to the "oxygen" gas connection on the rear of the solids module. Set an inlet pressure of 400 to 600 kPa on the pressure reducer.
- ▶ Connect the supplied serial data cable to the "HT" connection on the rear of the analyzer. Connect the other end of the data cable to the solids module.
- ▶ Switch on the components of the analysis system. Start the software.
- ▶ Open the **Instrument** | **Instruments** menu option. Create a device configuration for solids analysis by clicking on the **Add** button.
- ▶ In **Furnace type** select the option **External horizontal** from the dropdown menu. Save the device configuration.
- ▶ Click on the **Set default** button to activate the device configuration as standard configuration.

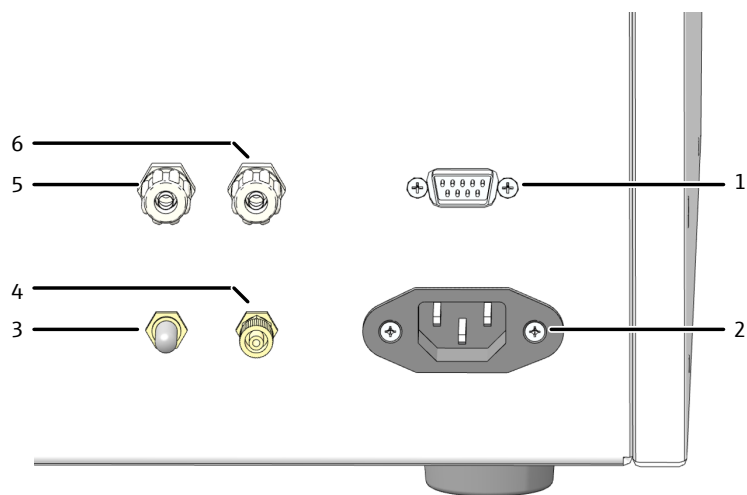

Fig. 38 Connections on the backplate of the solids module

- | | |
|------------------------------|--------------------------------------|
| 1 Analyzer interface | 2 Power connection |
| 3 Measuring gas outlet "OUT" | 4 Oxygen inlet "O ₂ " |
| 5 Pump connection "pump" | 6 Measuring gas connection "analyte" |

5 Operation

5.1 General notes



WARNING

Risk of chemical burns from concentrated acids

Concentrated acids are highly corrosive and sometimes have an oxidizing effect.

- Wear safety goggles and protective clothing when handling concentrated acids. Work under an extractor.
- Observe all instructions and specifications in the safety data sheets.



CAUTION

Risk of poisoning from sodium persulfate

The strong oxidizing agent sodium peroxide is toxic when ingested. The salt irritates skin, eyes and respiratory pathways. Contact can cause allergic reactions, respiratory problems or asthma-like symptoms.

- Wear safety goggles and protective clothing when handling sodium persulfate. Work under an extractor.
- Observe all instructions and specifications in the safety data sheet.
- When analyzing samples with high acidic or saline content, aerosols can form in the TIC condensation vessel. The capacity of the halogen trap is then depleted relatively quickly. The water trap also clogs up quickly. Both components have to be replaced frequently if this is the case. If possible, dilute such samples before measurement, for example 1:10. Alternatively, use a smaller volume of sample.
- When significant aerosol formation occurs, the analyzer is immediately protected by the integrated aerosol trap (water trap) and the carrier gas supply is automatically interrupted. Additionally, to protect the analyzer, remove the hose of the water trap on the front side.
- To acidify samples, use analytically pure acid (H_2SO_4 (2 mol/l)) and make it out of concentrated acid and TOC water.
- The autosamplers use the following acid volumes for the automatic acidification of samples:

Capacity of the sample container	Acid volume
12 ml	50 μl
20 ml	100 μl
40 ml	200 μl
50 ml	250 μl
100 ml	500 μl

- For TIC detection, only use orthophosphoric acid (H_3PO_4 , 10 %) made from concentrated acid (p.a.) and TOC water.
- For wet chemical UV digestion, prepare the following oxidant: Dissolve 80 g of sodium persulfate solution $\text{Na}_2\text{S}_2\text{O}_8$ and 10 ml of concentrated sulfuric acid H_2SO_4 in one liter of TOC water. Acid concentration in the finished solution: H_2SO_4 (2 mol/l).

- Solutions made from the following are suitable as standard solutions: Potassium hydrogen phthalate, sodium carbonate/sodium hydrogen carbonate, sucrose.
- Only clean, particle-free glass containers (volumetric flasks, sample vessels) may be used for the preparation and storage of the solutions.
- When preparing and storing solutions with very low concentrations (<1 mg/l), observe that the laboratory air components (CO₂, organic vapors) can change the solution concentrations. The following measures can remedy this:
 - Keep the free space above liquids, the so-called headspace, as small as possible.
 - During autosampler operation, cover the vessels on the sample tray with foil. This is important in particular with differential mode, as the samples remain on the sample tray for a longer time.
 - Eliminate the source of organic vapors.
 - Optionally: Fill the headspace above the samples with inert gas.

5.2 Switching on the analyzer



NOTE

Risk of device damage due to depleted copper wool

Damage to optical and electronic components of the analyzer due to aggressive combustion products when the copper wool in the halogen trap is depleted!

- Only use the device with an operational halogen trap!
- Replace the complete filling of the halogen trap when half of the copper wool or brass wool is discolored!

The software can support you with a checklist for the daily start of the analysis system. To do this create the checklist under **Program | Settings** in the **Instrument initialization** section.

Before switching on the analyzer, check the following:

- The waste hose is connected to a suitable waste container. Free flow is ensured. The capacity of the waste container is sufficient.
- The gas supply is connected in accordance with regulations and the inlet pressure is 400 to 600 kPa.
- There is enough phosphoric acid in the reagent bottle. A volume of 1 ml acid is required per TIC determination.
- There is enough sodium persulfate solution in the reagent bottle. A volume of 2 ml is required per TOC, TC and NPOC measurement.
- The halogen trap is connected, filled with copper and brass wool. The copper and brass wool not used up.
- All hoses are properly connected and in good working order.
- All optional accessories (autosamplers, solids modules, etc.) are connected.

Prepare the sample and switch on the analyzer as follows:

- ▶ Open the valve on the pressure reducer of the gas supply.
- ▶ Switch on the PC.
- ▶ Switch on the components of the analysis system.
- ▶ Finally, switch on the analyzer at the main switch. The analyzer is ready for operation when the status LED on the left front door lights up green.

- ▶ Start the software using the Windows start command **Start | multiWinPro** or by double clicking on the software icon on the desktop.
- ▶ In the login window, enter the user name and password. Click **OK** to confirm the entered data.
- ▶ Initialize the analysis system by clicking on **Initialize instrument** in the **Instrument control** panel.
If you activate the **Auto-Initialization on start** option under **Program | Settings**, the software will automatically initialize the analysis system when the software starts.
 - ✓ The software initializes the analysis system and activates the standard configuration.
- ▶ Use the **Instrument | Instruments** menu option to change the device configuration if needed. Activate the desired device configuration by clicking on the **Set default** button or by double-clicking.
- ▶ Wait for the end of the warming-up phase (15 min).
- ▶ The analysis system is not ready for measurement after the warm-up phase if components in the **Instrument status** panel are displayed in color. If so, start troubleshooting. First check the hoses for tight fit.
- ▶ Set the purge flow for NPOC measurements.
To do this, activate the purge flow via the **Instrument | Single control steps | Purge** menu command.
Set the gas flow at the "NPOC" needle valve.
- ▶ Adjust the autosampler after each modification. To do this, open the **Sampler alignment** window using the menu option **Instrument | Sampler alignment**.
 - ✓ The analysis system is ready for measurement.

See also

 Troubleshooting [▶ 85]

5.3 Switching off the analyzer

Standby

Switch the analyzer system to standby for measurement breaks of ≥ 30 min, for example while you are evaluating measurement results or overnight.

In standby mode, the software reduces the gas flow and switches off the UV lamp.

- ▶ Select the **Instrument | Standby** menu option.
- ▶ Or: In the **Instrument control** panel click on the **Instrument standby or switch off** button.
 - In **Standby** select the option **Standby**.
- ▶ Flush the analysis device, for measurements without autosampler:
 - Activate the checkbox **Reverse rinse**. Hold the sample intake cannula in the waste canister.
- ▶ Flush the analysis device, for measurements with AS vario, EPA Sampler autosampler:
 - Activate the checkbox **Reverse rinse**. The content of the sample intake hose is automatically washed back into the wash cup.
- ▶ Flush the analysis device, for measurements with AS 10e, AS 21hp autosampler:

- At the end of the sequence, measure one sample of ultrapure water.
(The autosamplers do not have the wash cup required for the backflush process.)
- ▶ Exit the dialog with **OK**.
 - ✓ The software stays open. The analysis system will be put in standby mode.

Switching off

Switch off the analysis system before long periods of inactivity, e.g. at weekends or during vacations.

The software switches off the gas flow and pumps out the TIC condensate container. The software switches off the UV lamp.

- ▶ Select the **Program | Close** menu option.
- ▶ Or: Shut down the software using the **X** icon (top right).
- ▶ Or: Select the **Instrument | Switch off** menu option.
- ▶ Or: In the **Instrument control** panel click on the **Instrument standby or switch off** button.
- ▶ In **Standby** select the option **Switch off**.
- ▶ Flush the analysis device, for measurements without autosampler:
 - Activate the checkbox **Reverse rinse**. Hold the sample intake cannula in the waste canister.
- ▶ Flush the analysis device, for measurements with AS vario, EPA Sampler autosampler:
 - Activate the checkbox **Reverse rinse**. The content of the sample intake hose is automatically washed back into the wash cup.
- ▶ Flush the analysis device, for measurements with AS 10e, AS 21hp autosampler:
 - At the end of the sequence, measure one sample of ultrapure water.
(The autosamplers do not have the wash cup required for the backflush process.)
- ▶ Exit the dialog with **OK**.
 - ✓ The software shuts down. The analysis system shuts down. You can now switch off the components of the analysis system at their main switches.

Standby / switch off at end of measurement

At the end of a sequence, you can automatically shut down the analysis system or put it into standby. For example, they can save gas and energy when measuring overnight.

- ▶ Use the **Measurement | Add new sequence** menu option to create a new sequence.
- ▶ Standby: At the end of the sequence use the **Add control step** button to set the **Standby instrument** control step. Set the standby temperature in the **Step properties** panel.
- ▶ If necessary, use the **Wake up** control step to make the analysis system ready for operation again at the desired time.
- ▶ Switching off: Set the control step **Turn off instrument** at the end of the sequence.



5.4 Performing measurements

5.4.1 Create sequence and measure with manual sample feed

Preliminary considerations:

- Blank values change over time. You should therefore decide whether to re-measure blank values at the start of the sequence.

- If necessary, you can correct the calibration with a daily factor. To do this, measure one or more standard solutions at the beginning of the sequence to determine the daily factor(s). The software automatically transfers the daily factors to the calibration if the daily factors are within the limits specified in the sequence in the **Step type properties** panel.
- ▶ Prepare one or more methods for manual sample feed. To do this, activate the **Manual measurement** checkbox in method parameters.
A sequence can contain sample steps with different methods. However, liquids and solids cannot be measured in a sequence.
Deactivate the **Automatic acidification** method parameter for manual measurements.
- ▶ Alternatively: Wait to activate the **Manual measurement** checkbox until the sequence was created in method parameters.
- ▶ Use the **Measurement | Add new sequence** menu option to create a new sequence.
- ▶ In the **Sequence properties** panel activate the **Is a solids measurement** checkbox for manual solids measurement.
- ▶ By default, the software assigns a new sequence to the active device configuration. If necessary, click on the  icon to assign the empty sequence to a different device configuration.
To do this, select a device configuration in the **Select instrument configuration** window. Confirm the selection by clicking on the **OK** button.
- ▶ Alternatively, open an already prepared sequence. Open the **Sequences** window using the menu option **Sequences | Sequences**. Select prepared sequence from the **Overview** table. Open the sequence by double-click or with **Load**.
- ▶ Create measurement steps in sequence with **Add by method**. Ensure that the method settings, such as the sample volume, match the device configuration.
- ▶ Select the method from the dropdown menu or in the **Add by method** window.
- ▶ Enter sample name in sequence table by double-click on measurement step or in the **Step properties** panel, Tab **Step**.
The default name is: method type + step number.
Optionally add a comment.
- ▶ If necessary, create several sample steps using the option **Add multiple steps** (in context menu).
 - Select the method in the window **Add multiple steps to sequence**.
 - Set the number of measurement steps under **Count of steps**.
 - Choose a common base word for the designation of the steps under **Base name**.
The default name is: sample + method type.
 - Start number in input field Enter **Use numbers**: to number the measurement steps.
 - Transfer the measurement steps to the sequence by clicking on **Create steps**.
- ▶ In case of manually diluted samples, enter the dilution ratio under **Dilution: Vol. sample** and **Dilution: total volume**: Parts of the primary sample in the total parts.
The software takes the dilution into account when calculating the results.
- ▶ If required, select one or more measurement steps in the sequence table and adjust the method settings in the **Step properties** panel to the measurement task.
After selecting a method setting, you can navigate from measurement step to measurement step by clicking on the Enter button.

- ▶ In the **Step properties** panel on the **Calibration** tab, view the calibration linked to the method for each measurement channel. The calibration coefficients are displayed under the drop-down menu.
If required, select a different calibration for calculating the measurement results from the drop-down menus.
If you do not link a calibration to the method or select it here, the software uses the standard calibration that is stored in the device parameters.
- ▶ View blank values for each measuring channel on the **Blanks** tab. Edit blank values if required.
The software automatically corrects the measurement results for any blank values. Unless you redefine the blank values at the start of the sequence, the software uses the last blank values.
- ▶ The software creates measurement steps with sample type **Sample**. Select measurement step and after clicking on the **Sample type** button, select other sample type, such as **Daily factor**, from the drop-down menu.
- ▶ Optionally specify lower and upper limit value for the measurement result in the **Step type properties** panel. Select actions from the dropdown menu if the limit is exceeded, such as **cancel** for measuring stop.
- ▶ Select result table from drop-down menu after clicking on **Result table**. Or: Create a new result table with **Create new result table**.
Unless you select a result table, the software saves the results in the default result table. For default setting see: **Program | Settings | Result table**
i NOTE! It is not possible to start a measurement without a results table.
- ▶ Check the finished sequence for plausibility by clicking on . The software checks whether the created measuring steps can be measured.
- ▶ If necessary, save the sequence with . Set the name for the sequence in the **Save as** window and confirm with **OK**. The software names the window accordingly.
- ▶ Provide samples. For liquid measurements, dip the sample intake cannula into the sample. For NPOC measurements, also insert a purge cannula into the sample.
- ▶ Before starting the measurement: Check device readiness in the **Instrument status** panel.
- ▶ Start the measurement by clicking on . Follow the instructions on the screen.
Remain next to the device during repeat measurements so that instructions can be followed and acknowledged.
 - ✓ The analysis system processes the sequence. You can add further steps to the sequence during the measurement.

The software displays the current measurement results during recording graphically in the lower window area and in a result table.



In the **Step results** panel you can view the results of already measured samples. When the sequence was processed, you can see the results in the **Results** menu.

5.4.2 Creating a sequence and measuring with automatic sample feed

Preliminary considerations:

- Blank values change over time. You should therefore decide whether to re-measure blank values at the start of the sequence.

- If necessary, you can correct the calibration with a daily factor. To do this, measure one or more standard solutions at the beginning of the sequence to determine the daily factor(s). The software automatically transfers the daily factors to the calibration if the daily factors are within the limits specified in the sequence in the **Step type properties** panel.
- ▶ Prepare one or more methods for the measurement.
A sequence can contain measurement steps with different methods. However, liquid and solids methods, for example, cannot be measured in a sequence.
Optionally, link one or more calibrations to the method.
- ▶ Provide samples on sample tray.
- ▶ Use the **Measurement | Add new sequence** menu option to create a new sequence.
- ▶ In the **Sequence properties** panel, configure settings that apply to multiple sequences:
Solids measurement, automatic or intelligent dilution, intelligent reduction of sample volume, and parallel purge for NPOC methods.
To do so, tick the corresponding checkbox.
The available options depend on the device configuration.
- ▶ By default, the software assigns a new sequence to the active device configuration. If necessary, click on the  icon to assign the empty sequence to a different device configuration.
To do this, select a device configuration in the **Select instrument configuration** window. Confirm the selection by clicking on the **OK** button.
- ▶ Alternatively, open an already prepared sequence. Open the **Sequences** window using the menu option **Sequences | Sequences**. Select prepared sequence from the **Overview** table. Open the sequence by double-click or with **Load**.
- ▶ Create measurement steps in sequence with **Add by method**. Ensure that the method settings, such as the sample volume, match the device configuration.
- ▶ Select the method from the dropdown menu or in the **Add by method** window.
- ▶ Enter sample name in sequence table by double-click on measurement step or in the **Step properties** panel, Tab **Step**.
The default name is: method type + step number.
Optionally add a comment.
- ▶ If necessary, create several sample steps using the option **Add multiple steps** (in context menu).
 - Select the method in the window **Add multiple steps to sequence**.
 - Set the number of measurement steps under **Count of steps**.
 - Choose a common base word for the designation of the steps under **Base name**.
The default name is: sample + method type.
 - Start number in input field Enter **Use numbers**: to number the measurement steps.
 - Transfer the measurement steps to the sequence by clicking on **Create steps**.
- ▶ The software creates measurement steps with sample type **Sample**. Select measurement step and after clicking on the **Sample type** button, select other sample type, such as **Daily factor**, from the drop-down menu.
- ▶ Determine position on sample tray under **Step properties | Tab Step** under **Sample position**.
You can occupy positions on the autosampler tray more than once in a sequence.

- ▶ If required, select one or more measurement steps in the sequence table and adjust the method settings in the **Step properties** panel to the measurement task. After selecting a method setting, you can navigate from measurement step to measurement step by clicking on the Enter button.
- ▶ In case of manually diluted samples, enter the dilution ratio under **Dilution: Vol. sample** and **Dilution: total volume**: Parts of the primary sample in the total parts. The software takes the dilution into account when calculating the results.
- ▶ In the **Step properties** panel on the **Calibration** tab, view the calibration linked to the method for each measurement channel. The calibration coefficients are displayed under the drop-down menu. If required, select a different calibration for calculating the measurement results from the drop-down menus. If you do not link a calibration to the method or select it here, the software uses the standard calibration that is stored in the device parameters.
- ▶ View blank values for each measuring channel on the **Blanks** tab. Edit blank values if required. The software automatically corrects the measurement results for any blank values. Unless you redefine the blank values at the start of the sequence, the software uses the last blank values.
- ▶ Optionally specify lower and upper limit value for the measurement result in the **Step type properties** panel. Select actions from the dropdown menu if the limit is exceeded, such as **cancel** for measuring stop.
- ▶ Click on the **Add control step** button to add control steps such as pauses or additional rinsing steps to the sequence.
- ▶ Add the control steps **Standby** or **Turn off instrument** at the end of the sequence in order to shut the analysis system down after sequence processing.
- ▶ Select result table from drop-down menu after clicking on **Result table**. Or: Create a new result table with **Create new result table**. Unless you select a result table, the software saves the results in the default result table. For default setting see: **Program | Settings | Result table**
- ▶ **i** NOTE! It is not possible to start a measurement without a results table.
- ▶ Check the finished sequence for plausibility by clicking on . The software checks whether the created measuring steps can be measured.
- ▶ If necessary, save the sequence with . Set the name for the sequence in the **Save as** window and confirm with **OK**. The software names the window accordingly.
- ▶ Before starting the measurement: Check device readiness in the **Instrument status** panel.
- ▶ Start the measurement by clicking on  .
 - ✓ The analysis system processes the sequence. You can add further measurement or control steps to the sequence during the measurement.

The software displays the current measurement results during recording graphically in the lower window area and in a result table.

In the **Step results** panel you can view the results of already measured samples. When the sequence was processed, you can see the results in the **Results** menu.

6 Maintenance and care

The operator may not undertake any service or maintenance work to this device and its components other than that specified in these instructions.

Observe the information in the "Safety instructions" section for all maintenance work. Compliance with the safety instructions is a prerequisite for the error-free operation of the device. Always observe all warnings and instructions that are displayed on the device itself or indicated by the control software.

To ensure faultless and safe functioning, Analytik Jena recommends an annual inspection and servicing by its Service department.

6.1 Maintenance overview

Analyzer

Maintenance interval	Maintenance task
Weekly	<ul style="list-style-type: none"> ▪ Clean and service the device. ▪ Clean the reagent bottle and the drip tray. ▪ Check the fastening screws for proper fit.

Sample supply system and autosampler

Maintenance interval	Maintenance task
Quarterly	<ul style="list-style-type: none"> ▪ Check the syringe pump for leaks.
Every 12 months	<ul style="list-style-type: none"> ▪ Clean the dosing syringe (earlier if required).
As required	<ul style="list-style-type: none"> ▪ After initial start, change of the sample tray or recommissioning after transport and storage: Adjust the autosampler.

Hose system

Maintenance interval	Maintenance task
Daily	<ul style="list-style-type: none"> ▪ Check the gas flow display in the Instrument status panel.
Weekly	<ul style="list-style-type: none"> ▪ Check the hose connections for proper fit.
Quarterly	<ul style="list-style-type: none"> ▪ Check the condensate pump for leaks.
Every 12 months	<ul style="list-style-type: none"> ▪ Replace the pump hose.

UV reactor

Maintenance interval	Maintenance task
Every 12 months	<ul style="list-style-type: none"> ▪ Check the intensity or oxidation capacity of the UV lamp.
As required	<ul style="list-style-type: none"> ▪ Clean the UV reactor.

Measuring gas drying and cleaning

Maintenance interval	Maintenance task
Daily	<ul style="list-style-type: none"> ▪ Check the filling of the halogen trap. ▪ If half of the copper or brass wool is discolored, replace the filling.
Quarterly	<ul style="list-style-type: none"> ▪ Check the TIC condensate container for cracks and damage.

Maintenance interval	Maintenance task
Every 6 months	<ul style="list-style-type: none"> Replace the water traps on the front side and the gas box.
Every 12 months	<ul style="list-style-type: none"> Clean the TIC condensate container and the condensation coil (earlier if required).

6.2 Adjustment and setting

6.2.1 General notes for adjusting the autosampler

During adjustment, the canulas are adjusted to the sample tray for optimum immersion in the sample vessels and/or wash cups.

An adjustment of the autosampler is necessary:

- Before the first start
- After each change of the sample tray
- During recommissioning after transport or storage

Adjustment of the AS 10e and AS 21hp autosamplers is described under Installation and Commissioning.

See also

- Installing and commissioning the sampler [▶ 43]

6.2.2 Adjusting the AS vario autosampler



NOTE

Risk of bending

The canula may bend during adjustment.

- Unscrew the screw connections on the canulas before adjustment.

- ▶ Start the software
- ▶ Use the **Instrument | Sampler alignment** menu option to open the **Sampler alignment** window.
- ▶ Aligning the canulas:
 - ▶ Select adjustment position **Needle** from the list box in the **Sampler position** section.
 - ▶ Click on the **Request current values** button to retrieve the current offset values.
 - ▶ Adjust the canulas with - **higher** / + **lower** until they stand about 2 cm above the adjustment points.
 - ▶ After each change, click **Move** to check the adjustment.
 - ▶ Align the canulas to the two adjustment points by carefully bending them.

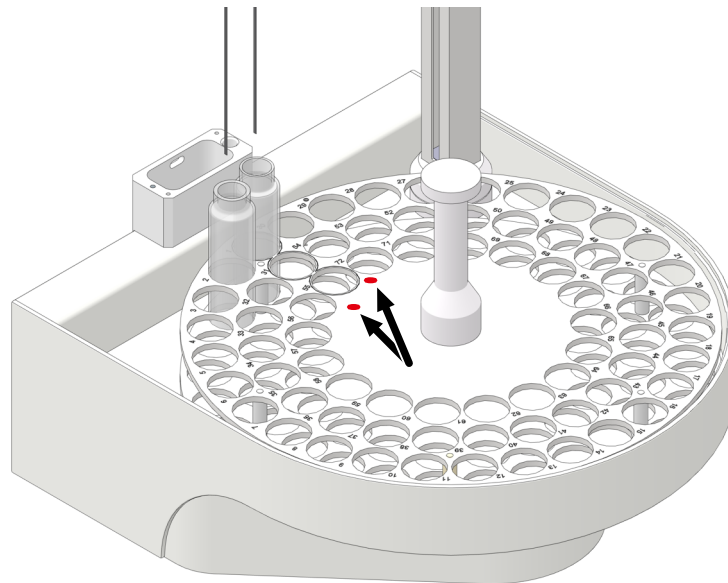



Fig. 39 Adjustment points on the sample tray

- ▶ Adjust the immersion depth of the sample intake canula into the wash cup and into a sample vessel in position 1 of the sample tray:

Sampler adjustment

AS Vario[72] at MultiNC 3300

Sampler Locations

Position	Offset X	Offset Y	Offset Z
Position 1	0 mm	0 mm	139 mm
Rinse	0 mm	0 mm	132 mm
Canula	0 mm	0 mm	132 mm

Request current offsets

Move to position

Select position : Move

Waste position : Move

Acid position : Move

position1

- higher / + lower 139

Move
Commit
Cancel

Fig. 40 Sampler alignment window

- ▶ At first, select the adjustment position **Rinse** from the list box in the **Sampler position** section.
- ▶ Modify the canula immersion depth via up-down control - **higher / + lower** until the canula dips at least 1 cm into the wash cup. Click on **Move** after each modification.
- ▶ For the AS vario ER autosampler: Lower the canula as far as possible into the wash cup so that the canula is sufficiently flushed with ultrapure water.
- ▶ After adjustment save offset values by clicking on **Confirm**. Close the window.
- ▶ Select adjustment position **Position 1** from the list box in the **Sampler position** section.
- ▶ Place a sample vessel with magnetic stirring rod on position 1 of the sample tray.
- ▶ Lower the cannulas to position 1 using the - **higher / + lower** up-down control into the sample vessel until the stirring rod can still rotate unhindered (distance approx. 5 mm).
- ▶ After adjustment save offset values by clicking on **Confirm**. Close the window.

- ▶ Select positions **Position 1** and **Waste position:** in the **Move to position** section and approach by clicking on **Move**.
 - ✓ The autosampler is adjusted.

Adjusting the autosampler for automatic acidification

The autosampler can automatically acidify samples for NPOC measurement. The immersion depth of the canula in the sample vessel depends on the adjustment for position 1.

- ▶ Open **Sampler alignment** window.
- ▶ Adjust the adjustment position **Position 1**.
- ▶ Place a sample vessel on the acid position. For the acid position see: **Acid position** in the **Move to position** section.
- ▶ Approach position by clicking on **Move** and check it.
- ▶ Apply offset values by clicking on **Confirm**.
- ▶ Check offset values by NPOC test measurement with automatic acidification.
- ▶ Ensure the canula goes through the sample lid but does not immerse in the sample liquid during acidification.

6.2.3 Adjusting the EPA Sampler



NOTE

Risk of bending

The canula may bend during adjustment.

- Unscrew the screw connections on the canulas before adjustment.

Clamp the two canulas high enough in the holder to prevent them dipping into the vessels (basic position).

During adjustment, the sample intake canula must be adjusted to the rinse position and to sample position 1. Alignment is carried out by increasing or decreasing the x-, y- and z-axis values.

For sample vessels with septum caps, special sample intake and purging canulas with piercing function are required: Piercing needles with ventilation slot.

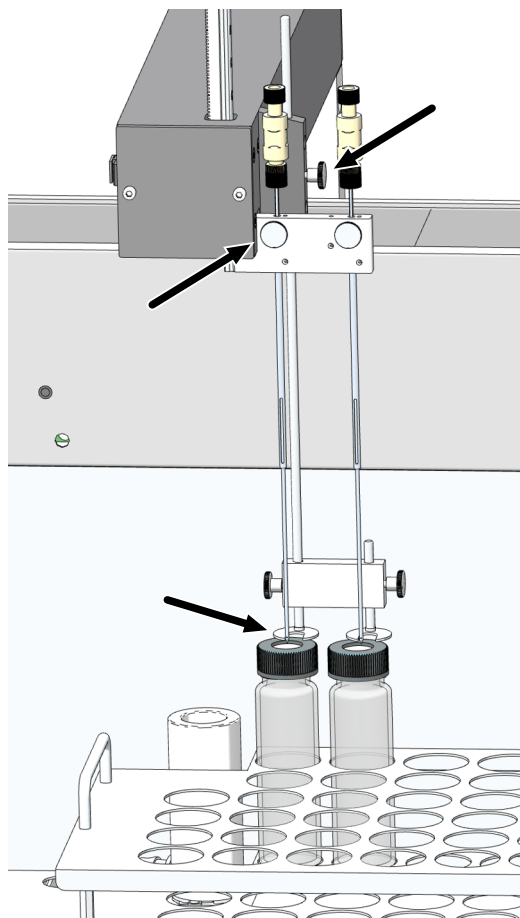

Fig. 41 Install canulas (here: 2 canulas for parallel purging)

- ▶ Install the hold-down clamp and the sample intake canulas in the canula holder. Unscrew the retaining screws of the canulas before adjustment. Clamp the canulas into the holder so that the canula tip does not immerse in the sample vessel.
- ▶ Use the **Instrument | Sampler alignment** menu option to open the **Sampler alignment** window.
- ▶ Adjust the immersion depth of the sample intake canula into the wash cup and into a sample vessel in position 1 of the sample tray.
- ▶ Select adjustment position **Position 1** from the list box in the **Sampler position** section.
- ▶ Click on the **Request current values** button to retrieve the current offset values.
- ▶ Change offset values in 0.1 mm steps using the up-down control - **backwards / + forwards** , - **left / + right** and - **higher / + lower**.

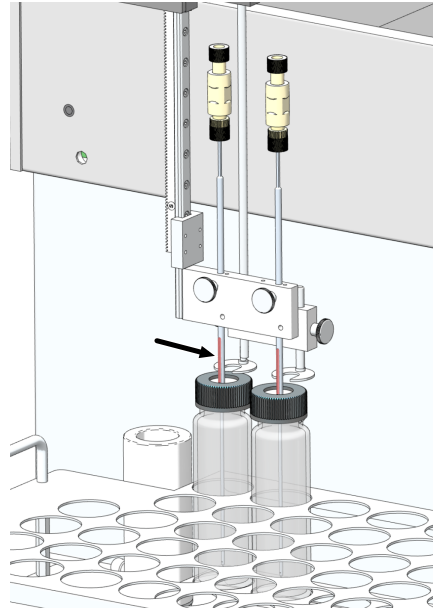

Fig. 42 Adjusting position 1

- ▶ First adjust position 1 without sample vessel. Place the magnetic stirring rod in position 1 on the sample tray.
- ▶ Align canula with up-down control - **backwards / + forwards** and - **left / + right** to make it stand centrally over Position 1.
- ▶ Insert a sample vessel with a screw cap and a septum cap, e.g., an EPA sample vessel, on Position 1 in the sample tray.
- ▶ Adjust the immersion depth of the special needle using up-down control - **higher / + lower** until approximately 2 cm of the ventilation slot can be seen above the septum. The ventilation slot must be located above and below the septum. No pressure compensation is otherwise possible in the sample vessel.
- ▶ After adjustment save offset values by clicking on **Confirm**. Close the window.
- ▶ Select adjustment position **Rinse** from the list box in the **Sampler position** section.
- ▶ Adjust the canula at the rinse position so that the canula is immersed in the center of the wash cup.
- ▶ Adjust the immersion depth of the special canula so that the ventilation slot can be seen at the upper edge of the wash cup.
- ▶ After each change, click **Move** to check the adjustment.
- ▶ After adjustment save offset values by clicking on **Confirm**. Close the window.
- ▶ Select positions **Position 1** and **Rinse** in the **Move to position** section and approach by clicking on **Move**.
 - ✓ The autosampler is adjusted.

Adjusting the autosampler for automatic acidification

The autosampler can automatically acidify samples for NPOC measurement. The immersion depth of the canula in the sample vessel depends on the adjustment for position 1.

- ▶ Open **Sampler alignment** window.
- ▶ Adjust the adjustment position **Position 1**.
- ▶ Place a sample vessel on the acid position. For the acid position see: **Acid position** in the **Move to position** section.
- ▶ Approach position by clicking on **Move** and check it.

- ▶ Apply offset values by clicking on **Confirm**.
- ▶ Check offset values by NPOC test measurement with automatic acidification.
- ▶ Ensure the canula goes through the sample lid but does not immerse in the sample liquid during acidification.

6.2.4 Setting the NPOC purge flow

The NPOC purge flow is preset to approx. 90 to 110 ml/min. Depending on the measurement task, you can increase or decrease the NPOC purge flow via the NPOC needle valve. The NPOC needle valve is on the device front behind the left-hand door.

Set the NPOC purge flow as follows:

- ▶ Open the **Single control steps** window with the **Instrument | Single control steps** menu option.
- ▶ For sample feed with autosampler: Select a random position on the sample tray in the **Sample purge** section at **Sample position** on which to observe the purge flow.
- ▶ Place a sample vessel with ultrapure water at this position.
- ▶ For manual sample supply: Insert purge hose 10 in a sample vessel filled with ultrapure water.
- ▶ Set the purge time at **Purge time**: 1 to 900 s.
- ▶ Click on **Purge**.
- ▶ Unscrew the adjustment screw on the NPOC needle valve.
- ▶ Set the desired NPOC purge flow:
 - Increase the NPOC purge flow: Turn the needle valve to the left.
 - Decrease the NPOC purge flow: Turn the needle valve to the right.
- ▶ Check the flow display in the **Instrument status** panel while doing this. The current NPOC purge flow is displayed with **Purge:**.
- ▶ Screw the adjustment screw on the needle valve back in.

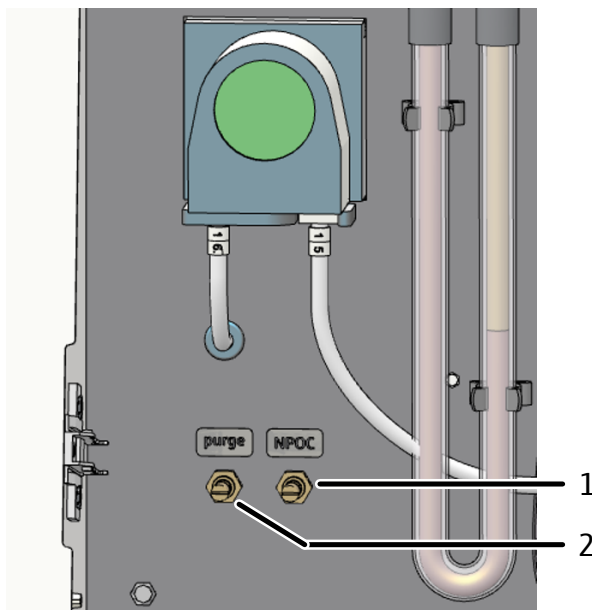

Fig. 43 Setting the NPOC purge flow

1 Needle valve for setting the NPOC purge flow

2 Needle valve for setting the reagent purge flow

6.3 Syringe pump maintenance

Clean or replace the dosing syringe of the syringe pump as follows:

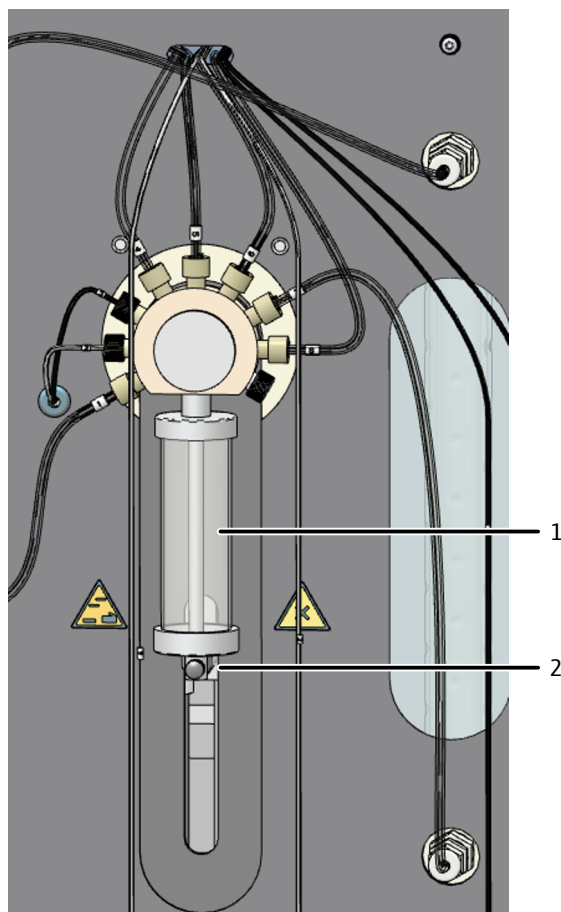

Fig. 44 Syringe pump maintenance

1 Glass cylinder

2 Drive shaft

- ▶ Open the doors of the analyzer.
- ▶ Open the window of the same name with the **Instrument | Single control steps** menu option.
- ▶ In the **Move syringe to change position** section click on the **Syringe change position** button.
 - ✓ The syringe is emptied and moved to the replacement position.
- ▶ Pull the hoses out of the ultrapure water bottle, the sample bottle and the reagents bottle and wipe them off with a clean paper towel.
 - ⚠ CAUTION! The hoses still contain reagents and acid.
- ▶ Remove the reagent bottles and drip trays from the analyzer.
- ▶ Unscrew the knurled head screw on the drive shaft.
- ▶ Unscrew the glass cylinder from the valve head.
- ▶ Dismantle the glass cylinder and piston and rinse these with ultrapure water.
- ▶ Reassemble the glass cylinder and piston. Screw the glass cylinder onto the valve head.
- ▶ Fasten the piston to the drive shaft with the screw.
- ▶ Place the drip trays and reagent bottles back in the analyzer.

- ▶ Insert the hoses in the ultrapure water bottle and reagent bottle.
 - Ultrapure water Hose 5
 - Reagent bottle with phosphoric acid: Hoses 2 and A
 - Reagent bottle with $\text{Na}_2\text{S}_2\text{O}_8$ solution Hoses 3 and B
 - ✓ The syringe pump is once again ready for operation.

6.4 Replacing the pump hose



CAUTION

Risk of chemical burns during hose replacement

Small quantities of acidic solutions can still be in the hoses.

- Wear protective gloves and clothing when replacing the hoses.
- Collect any leaking liquids with an absorbent sheet.

Check the pump hoses every 3 months for leaks and replace them after 12 months at the latest.

Condensate pump

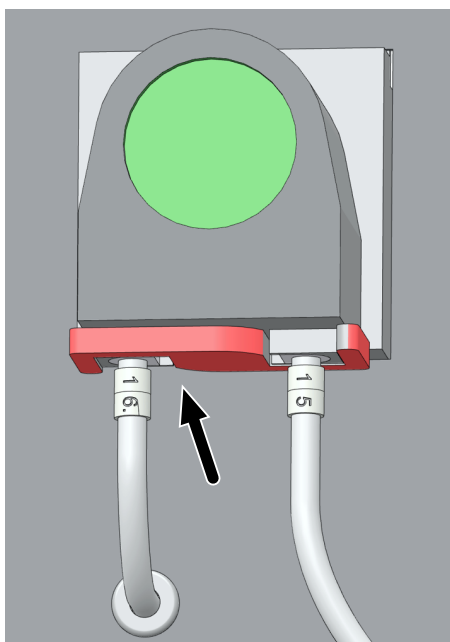

- ▶ Shut down control and evaluation software or turn off the gas flow with the **Instrument | Gas flow off** menu option.
- ▶ Open the doors of the analyzer.
- ▶ Press the bracket on the condensate pump to the left.
- ▶ Pull hoses 15 and 16 off of their connections.

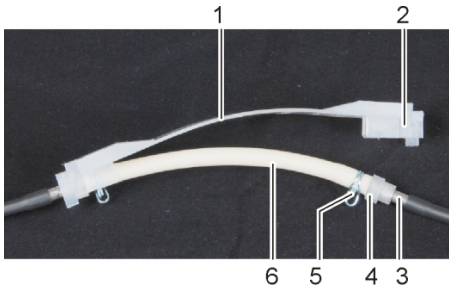

- 1 Guide piece
- 2 Groove
- 3 Metal connection
- 4 Hose guide
- 5 Hose clamp
- 6 Pump hose

- ▶ Remove the guide piece with the pump hose from the pump body.
- ▶ Check the pump hose and the connections for excessive wear and cracks. If moisture escapes the pump hose or the connections, replace the pump hose.
- ▶ Wipe the pump body and the roller carrier with ultrapure water.
- ▶ Check the pump body and roller carrier for wear.
- ▶ Press the still-intact or new pump hose back into the guide piece. Align the hose clamps downward during installation.
- ▶ Insert the hose guide in the groove of the guide piece.

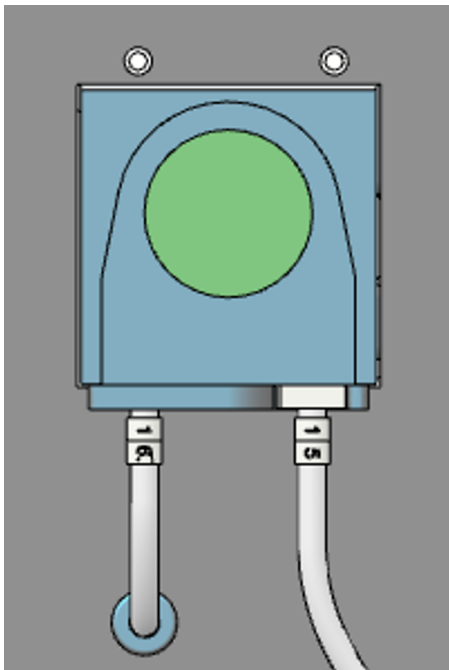

- ▶ Position the guide piece around the pump body.
- ▶ Press the guide piece upward with one hand. Turn the clip to the right until it engages with the other hand.
- ▶ Push hoses 15 and 16 back onto their adapters.
- ▶ Switch on the gas supply again and check the system for leaks.
 - ✓ The pump is once again ready for operation.

6.5 Replacing the hose connections

FAST connectors connect hoses with glass components. Use the threading aid to feed thin hoses into the connectors. This is included with the analyzer. Check the system for leaks after hose replacement.



- ▶ Slide the FAST connector onto the canula of the threading aid. The narrow hole of the connector points upwards.

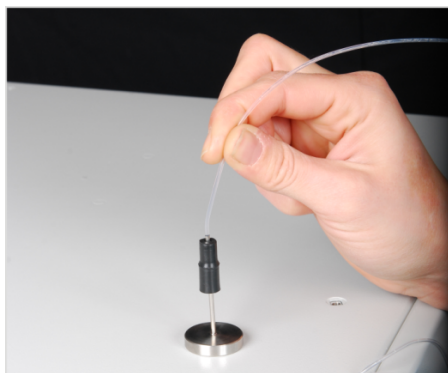

- ▶ Thread the hose into the canula of the threading aid.

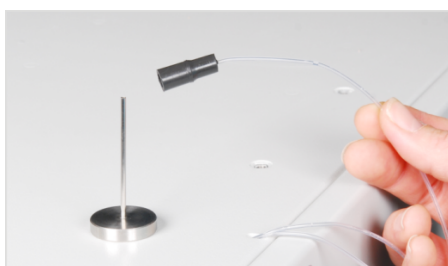

- ▶ Slide the FAST connector from the canula onto the hose.
- ▶ Pull the hose out of the canula of the threading aid. Pull the hose of the FAST connector until it no longer reaches into the wider hole.

Angled FAST connectors

With angled FAST connectors, do not slide the hose ends beyond the side length of the connector. The gas flow will otherwise be impaired.

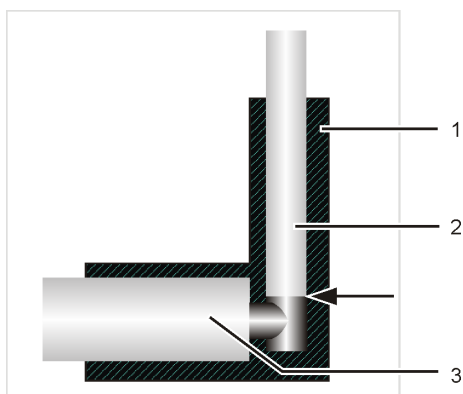

Fig. 45 FAST connector, angled

- 1 Angled FAST connector
- 2 Hose
- 3 Glass connection

Fingertight connections

- ▶ When replacing Fingertight connections, only use straight cut, round, uncrimped hose ends.
- ▶ Slide the conical nipple onto the hose with the conical side towards the banjo bolt. The conical nipple and hose end must be flush.
- ▶ Do not jam the banjo bolt during insertion and only tighten it hand-tight.

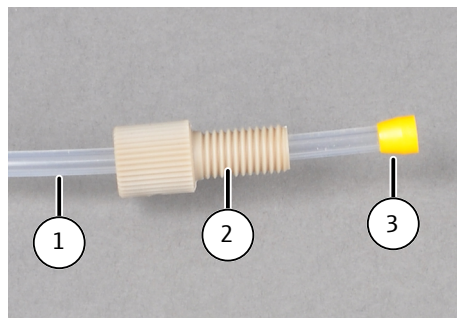

Fig. 46 Replacing the Fingertight connection

- | | |
|------------------|--------------|
| 1 Hose | 2 Banjo bolt |
| 3 Conical nipple | |

6.6 Checking the system for leaks



NOTE

Risk of gas leakage

When the outlet flow is significantly less than the inlet flow, the device system has a gas leak.

- Check all connection pieces, for example with a foamy tenside solution.
- Only put the device into operation when the gas leak has been eliminated.

The system tightness is automatically checked at the gas outlet of the analyzer.

- ▶ Switch on the analyzer.
- ▶ Open the carrier gas supply on the pressure reducer.
- ▶ Start the control and analysis software.
- ▶ Check the flow display in the **Instrument status** panel:
 - **In:** (inlet flow) 140 ml/min
 - **Out:** (outlet flow) 130 to 150 ml/min

6.7 UV reactor maintenance

Check the intensity of the UV lamp every 12 months to ensure complete sample digestion.

The software indicates when the set maintenance interval of the UV reactor is about to expire. Recommended maintenance interval: 5000 injections.

- If the lamp intensity is insufficient, clean the UV reactor.
- If cleaning does not improve results, customer service must replace the UV reactor.

After maintenance of the UV reactor, reset the injection counter to zero with the **Reset counter** menu command in the **Instruments** window on the **Maintenance** tab.

6.7.1 Checking the illumination of the lamp

To test the lamp intensity, perform one TOC measurement with sodium persulfate and another TOC measurement without. Form the quotient from the results of both measurements and multiply this by 100 %. The oxidation capacity of the UV lamp is only sufficient if the quotient is at 85 to 115 %.

Use a standard sucrose solution (10 mg/l) for the test.

Method configuration

Method type	NPOC (liquid measurement)
Add reagent	One measurement with, one measurement without addition of sodium persulfate
No. replicates, Max. replicates	Min. 2, max. 3
Sample volume	5000 µl
Purge time 1	300 s

Measurements

Measurement	Description	Result
1	Measurement without sodium persulfate, oxidation only via UV lamp	Surface integral FE ₁
2	Measurement with sodium persulfate as an additional oxidant	Surface integral FE ₂

Calculation

$$\text{Quotient} = \text{FE}_1 \times 100 \% / \text{FE}_2$$

If the quotient is greater than 85 to 115 %, prepare a new standard solution and oxidant and repeat the test.

If the quotient is less than 85 to 115 %, contaminants may be affecting the performance of the UV reactor. Clean the UV reactor.

6.7.2 Cleaning the UV reactor

- ▶ Clean the UV reactor with the oxidant reagent: Na₂S₂O₈ solution (80 g/l). Do not remove the UV reactor for cleaning.
- ▶ Dip the sample intake canula into the reagent bottle filled with Na₂S₂O₈ solution and start a manual measurement.
- ▶ After completing the cleaning process, carry out additional flushing measurements using ultrapure water in NPOC mode. Use the maximum injection volume of 20000 µl here as well and carry out 2 to 3 determinations.
- ▶ Recheck the lamp intensity again after cleaning.

Method configuration

Method type	TC (liquid measurement)
Manual measurement	Manual sodium persulfate feed
Add reagent	Measurement with addition of sodium persulfate
No. replicates, Max. replicates	Min. 2, max. 3
Sample volume	20000 µl
Rinse volume	2500 µl
Maximum integration time	600 s
Flushing cycles (on Tab Replicates)	Replicate 1: 1 Replicate 2, 3, 4: 0

6.8 Cleaning the TIC condensate vessel



WARNING

Risk of chemical burns from phosphoric acid

The TIC condensate container contains phosphoric acid. Phosphoric acid can irritate eyes, skin and mucous membranes.

- Wear safety goggles and protective clothing when handling concentrated acids. Work under an extractor.
- Observe all instructions and specifications in the safety data sheet.

Check the TIC condensate container regularly for deposits. Only clean the TIC condensate container when the samples are no longer purged correctly.

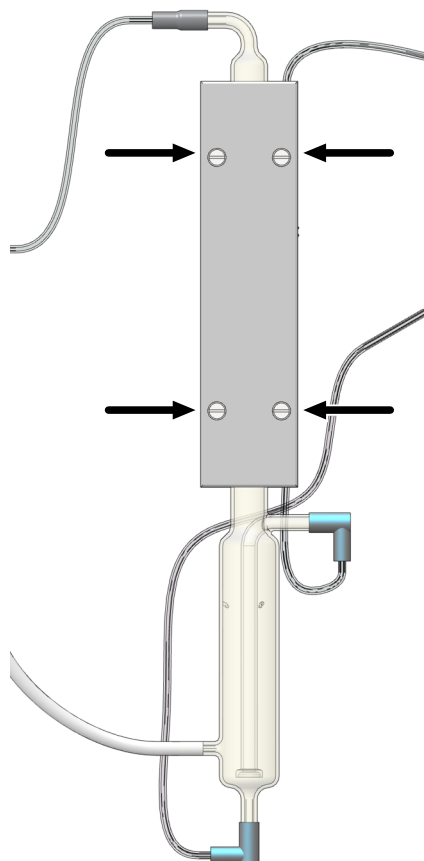

- ▶ Shut down control and evaluation software or turn off the gas flow with the **Instrument | Gas flow off** menu option.
- ▶ Open the doors of the analyzer.
- ▶ Pull the hoses out of the ultrapure water bottle, the sample bottle and the reagents bottle and wipe them off with a clean paper towel.
 - ⚠ CAUTION! The hoses contain residue from acids and reagents.
- ▶ Remove the reagent bottles and drip trays from the analyzer.
- ▶ Unscrew the four screws on the cover of the cooling block (see arrows).
- ▶ Remove the cover and the metal plate below.
- ▶ Remove the TIC container from the tray.
- ▶ Pull the hoses out of the FAST connectors. Remove the FAST connectors from the TIC condensate container.
- ▶ Check the TIC condensate container for deposits and cracks and rinse it with ultrapure water.

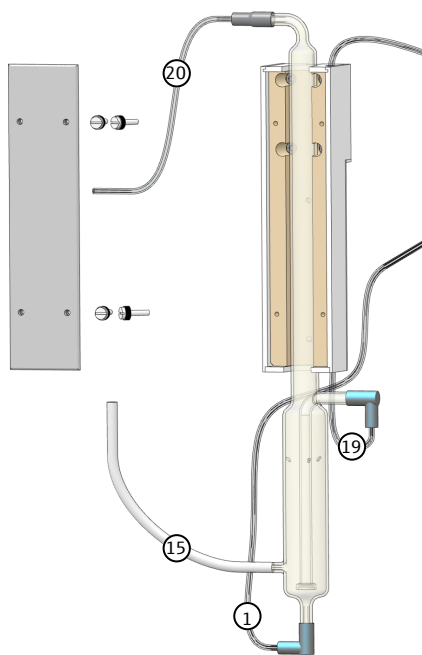

- ▶ Fasten the hoses in accordance with the image:
 - Slide waste hose 15 at least 1 cm onto the bottom side connection of the TIC condensate container.
 - Slide hoses 1, 19 and 20 into the FAST connectors first. Slide the hoses with FAST connectors onto the connections of the TIC condensate container.
 - Route hoses 1 and 15 behind the halogen trap.
- ▶ Insert the TIC condensate container in the cooling block. Put the metal plate and the cover back on.
- ▶ Fasten the cover of the cooling block with the four screws.
- ▶ Place the drip trays and reagent bottles back in the analyzer.
- ▶ Insert the hoses in the ultrapure water bottle and reagent bottles.
- ▶ Reactivate the gas supply with the **Instrument | Gas flow on** menu option.
 - ✓ The TIC condensate container is again ready for operation.

6.9 Replacing the water traps

Replace the water traps dependent on the sample matrix, but no later than after 6 months.

The water traps consist of a prefilter and a disposable retention filter. Always replace both water traps. Observe that the water traps only function properly if they are installed in the correct order and direction.

Check the system for leaks after replacing the water traps.

Water traps on the front side

You can replace the water traps on the front side while the device is switched on, but not during a measurement.

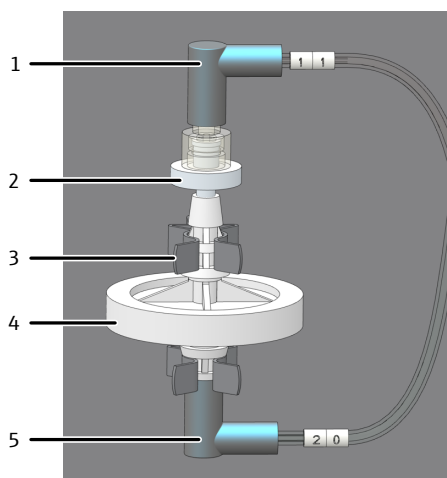

Fig. 47 Replacing the water traps on the front side

- | | |
|-----------------------------|-------------------------------|
| 1 FAST connector to hose 11 | 2 Disposable retention filter |
| 3 Clamps | 4 Aerosol trap as prefilter |
| 5 FAST connector to hose 20 | |

- ▶ Open the doors of the analyzer.
- ▶ Remove the FAST connectors on the upper and lower sides of the water traps.
- ▶ Assemble the new water traps:
 - The "INLET" marking on the large water trap (aerosol trap) must face downward.
 - The labeling on the small water trap (disposable retention filter) must face upward.
- ▶ Connect the FAST connectors on the top small water trap and the bottom large water trap.
- ▶ Press the water traps into the clamps on the device wall.
- ▶ Check the system for leaks.
- ▶ Close the front doors again.

Water traps on the gas box

Two water traps are installed in front of the gas box (prefilter and disposable retention filter). They protect the gas box from aerosols and rising water in case of incorrect gas pressures. The left side wall of the analyzer must be opened to replace the water traps.



CAUTION

Risk of burns on the UV module

The UV reactor remains hot immediately after switching off the device.

- Wait at least 30 min for the UV reactor to cool down before removing the UV module.

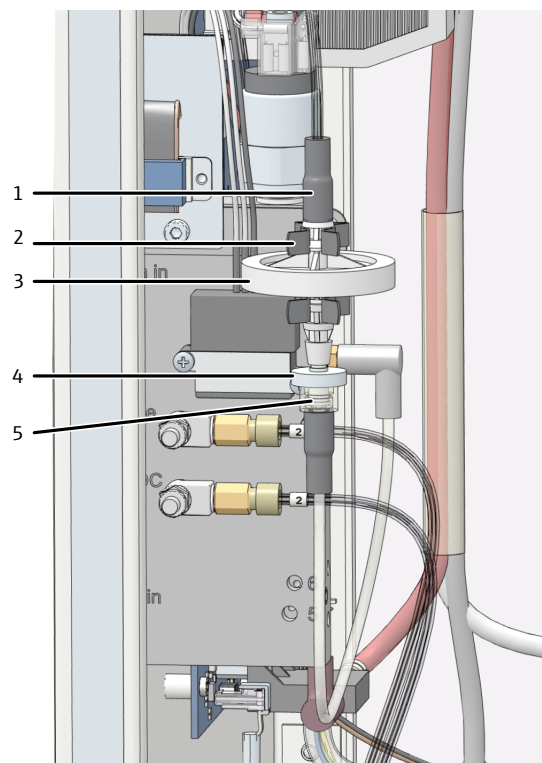

Fig. 48 Replacing the water traps on the gas box

- | | |
|---------------------------------------|-------------------------------|
| 1 FAST connector | 2 Clamp on the gas box |
| 3 Prefilter (aerosol trap) | 4 Disposable retention filter |
| 5 Luer connection with FAST connector | |

- ▶ Exit the control and analysis software.
- ▶ Switch off the analyzer using the power switch. Disconnect the power plug from the socket. Allow the analyzer to cool down.
- ▶ Open the left side wall of the analyzer. Push the accessory modules to the side if necessary. Do not kink any connection hoses.
 - Unscrew the four attachment screws. The screws are captive and remain attached to the wall.
 - Remove the protective grounding. Set the side wall aside safely.
- ▶ Pull the water traps out of the two clamps on the gas box.
- ▶ Pull the upper FAST connector off of the water traps.
- ▶ Remove the water traps from the Luer connection.
- ▶ Assemble the new water traps:
 - The "INLET" marking on the large water trap (aerosol trap) must face upward.
 - The labeling on the small water trap (disposable retention filter) must face downward.
- ▶ Connect the large water trap with the upper FAST connector.
- ▶ Connect the small water trap to the Luer connection on the bottom.
- ▶ Press the water traps into the clamps on the gas box.
- ▶ Close the side wall.
 - Connect the protective grounding to the left side wall.
 - Slightly tighten the screws first on the bottom side and then on the top side. Tighten the screws in turns.
- ▶ Connect the power plug with the socket and switch on the analyzer again via the main switch.
- ▶ Check the system for leaks.
 - ✓ The water traps on the front side and the gas box are replaced.

See also

📖 Checking the system for leaks [▶ 78]

6.10 Replacing the halogen trap



NOTE**Risk of device damage due to depleted copper wool**

Damage to optical and electronic components of the analyzer due to aggressive combustion products when the copper wool in the halogen trap is depleted!

- Only use the device with an operational halogen trap!
- Replace the complete filling of the halogen trap when half of the copper wool or brass wool is discolored!

The analyzer can remain switched on to replace the used copper and brass wool.

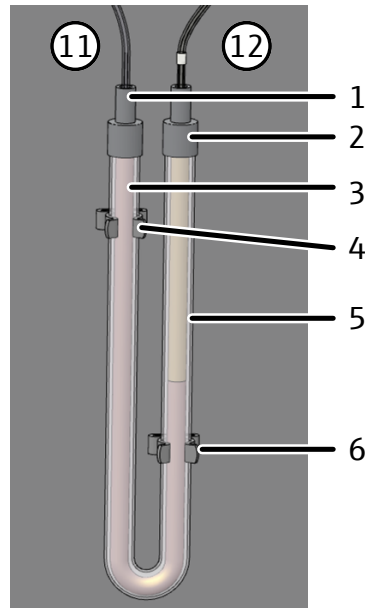

Fig. 49 Replacing the halogen trap

- | | |
|-----------------------------|-----------------------------|
| 1 FAST connector to hose 11 | 2 FAST connector to hose 12 |
| 3 Copper wool | 4 Clamp |
| 5 Brass wool | 6 Clamp |

- ▶ Open the doors of the analyzer.
- ▶ Remove the FAST connectors from the halogen trap and remove the U-tube from the clamps.
- ▶ Pull out the depleted copper wool or brass wool from the U-tube with tweezers or a small hook.
- ▶ Check the U-tube for cracks. Only reuse a fully intact U-tube.
- ▶ If necessary, rinse the U-tube with ultrapure water and allow it to dry well.
- ▶ Fill the U-tube with new copper wool and brass wool using tweezers or a small hook.
 - Replace the complete contents of the U-tube. Do not pack the copper and brass wool too tightly, but do not allow any larger empty spaces.
- ▶ Cover the copper wool and the brass wool with cotton wool.
- ▶ Carefully press the filled U-tube into the clamps again.
- ▶ When doing this, route hoses 1 and 15 behind the halogen trap.
- ▶ Reconnect the gas hoses with FAST connectors to the halogen trap:
 - Hose 11 to the branch with copper wool (connection to the water trap)
 - Hose 12 to the branch with brass wool (connection to the detector)
- ▶ Check the system for leaks.
- ▶ Close the doors of the analyzer again.

7 Troubleshooting



NOTE

Risk of device damage

Contact customer service in the following cases:

- The troubleshooting measures described do not eliminate the error.
- The error occurs repeatedly.
- The error message is not featured in the following list or the list refers to customer service for troubleshooting the error.

The system is monitored as soon as the device is switched on. After starting the control software, all malfunctions of the device are reported using error messages. Error messages consist of an error code and an error message.

The following section describes a number of possible malfunctions which the operator can partly troubleshoot without the help of a customer service technician. Confirm the error message and carry out the troubleshooting measures.

The software records log files. Make the log files available to customer service after consultation in the event of a fault.

- ▶ Use the **Help | Logs | Application log folder** and **Traffic log folder** menu options to open the log file folders.
- ▶ Send the current log files to customer service by e-mail. Use **Help | Contact service** to do this.

7.1 Software error messages

Error code: Error message	/: Device disconnected
Cause	Remedy
<ul style="list-style-type: none"> ▪ Interruption of the USB connection and thus the data transfer ▪ Severe voltage fluctuations in the mains supply 	<ul style="list-style-type: none"> ▪ Wait until the analyzer has completed the current action. If the error occurs during a measurement, the measurement is aborted with the error message. ▪ Reinitialize the analyzer with the Initialize button (in the Instrument control panel). ▪ If initialization is not possible, restart the software. ▪ If an error message is displayed indicating that the port is not available, switch the analyzer off and then on again.

Error code: Error message	1: Incomplete command from the PC 2: PC command without STX 3: PC command without * 4: PC command CRC error 5: PC command invalid command 6: PC command invalid MESS command
Cause	Remedy
<ul style="list-style-type: none"> Faulty connection between the internal and external program 	<ul style="list-style-type: none"> Initialize the analyzer.
Error code: Error message	7: COM 2 not found 8: COM 3 not found 9: COM 4 not found
Cause	Remedy
<ul style="list-style-type: none"> Internal hardware problems 	<ul style="list-style-type: none"> Switch the analyzer off/on.
Error code: Error message	10: Gas pressure error
Cause	Remedy
<ul style="list-style-type: none"> Counterpressure in the analysis system too high: The carrier gas supply is automatically interrupted to protect the analyzer. In: flow indication is approx. 0 ml/min. The water trap is clogged. 	<ul style="list-style-type: none"> Search for and replace the component causing the gas pressure error, see below. Detach the lower outlet of the water traps (hose 20) and reinitialize the analyzer. Check if the gas pressure error occurs again. If not, replace the water traps.
Error code: Error message	12: Incorrect version number
Cause	Remedy
<ul style="list-style-type: none"> The version of the control software and the software of the internal computer do not match. 	<ul style="list-style-type: none"> Perform a software update.
Error code: Error message	13: No connection to sampler
Cause	Remedy
<ul style="list-style-type: none"> The autosampler is not switched on. The connection cable is not connected or is faulty. 	<ul style="list-style-type: none"> Switch on the autosampler and initialize the analyzer. Check the connection cables.
Error code: Error message	15: Flow-error / no carrier gas
Cause	Remedy
<p>System is leaking:</p> <ul style="list-style-type: none"> UV reactor faulty (fractures on the connections). TIC condensate container faulty (fractures on the connections). The connections on the TIC condensate container are leaky. The connection on the water traps are leaky. The aerosol/water trap is clogged. The hose pump is leaky. 	<ul style="list-style-type: none"> Check the glass components. If these are defective, replace these with new ones. Check the FAST connectors on the TIC condensate container and the water traps. Replace the water traps. Check the hose pump. If necessary, replace the pump hose. Initialize the analyzer.

Error code: Error message	20: No connection to optics (NDIR) 21: CRC error optics 22: Status error optics 26: Optics error; incorrect command return
Cause	Remedy
<ul style="list-style-type: none"> ▪ Communication error ▪ NDIR detector faulty. 	<ul style="list-style-type: none"> ▪ Initialize the analyzer. ▪ Inform the service.
Error code: Error message	24: Optics error. analog values out of range
Cause	Remedy
<ul style="list-style-type: none"> ▪ The analog values of the detector are outside of the working range. 	<ul style="list-style-type: none"> ▪ Check the quality of the carrier gas. ▪ Initialize the analyzer and check the analog values via the component test.
Error code: Error message	27: Optics error. analog values out of range
Cause	Remedy
<ul style="list-style-type: none"> ▪ The analog values of the detector are outside of the working range. 	<ul style="list-style-type: none"> ▪ Check the quality of the carrier gas. ▪ For solids methods and connection of the HT 1300 module: Set the carrier gas flow higher than the intake flow. ▪ Initialize the analyzer and check the analog values via the component test.
Error code: Error message	40: No connection to the syringe pump
Cause	Remedy
<ul style="list-style-type: none"> ▪ No communication between the analyzer and the syringe pump. 	<ul style="list-style-type: none"> ▪ Initialize the analyzer. ▪ Switch the PC off and back on again and initialize the analyzer.
Error code: Error message	80: No connection to temperature controller
Cause	Remedy
<ul style="list-style-type: none"> ▪ No connection to the solids module. ▪ The solids module is not switched on. ▪ Incorrect connection. 	<ul style="list-style-type: none"> ▪ Check the connection cables. ▪ Switch on the optional solids module. ▪ Check the connection.
Error code: Error message	82: Thermocouple HT furnace interruption (HT)
Cause	Remedy
<ul style="list-style-type: none"> ▪ Faulty thermocouple. ▪ Furnace not connected. ▪ The furnace temperature is too high 	<ul style="list-style-type: none"> ▪ Inform the service. ▪ Connect the furnace. ▪ Inform the service.
Error code: Error message	82: UV cover open (UV)
Cause	Remedy
<ul style="list-style-type: none"> ▪ The contact on the UV cover is not closed, for example after the UV module has been replaced. 	<ul style="list-style-type: none"> ▪ Close the cover.
Error code: Error message	84: Communication error HT furnace temperature controller
Cause	Remedy
<ul style="list-style-type: none"> ▪ Communication error. 	<ul style="list-style-type: none"> ▪ Inform the service.

Error code: Error message	86: No external furnace found
Cause	Remedy
<ul style="list-style-type: none"> No connection to the solids module. 	<ul style="list-style-type: none"> Check the connection cables.
Error code: Error message	111: Rotator error
Cause	Remedy
<ul style="list-style-type: none"> The drive is incorrectly positioned, e.g. jammed. The drive is faulty. 	<ul style="list-style-type: none"> Initialize the analyzer. If the error cannot be corrected, contact the service.
Error code: Error message	112: Swivel drive error
Cause	Remedy
<ul style="list-style-type: none"> The drive is incorrectly positioned, e.g. jammed. The drive is faulty. 	<ul style="list-style-type: none"> Initialize the analyzer. If the error cannot be corrected, contact the service.
Error code: Error message	113: Lifting drive error / Sampler: z drive error (steps lost)
Cause	Remedy
<ul style="list-style-type: none"> The drive is incorrectly positioned, e.g. jammed. The drive is faulty. 	<ul style="list-style-type: none"> Initialize the analyzer. If the error cannot be corrected, contact the service.
Error code: Error message	114: Rack detection error
Cause	Remedy
<ul style="list-style-type: none"> The sample tray is not positioned correctly. 	<ul style="list-style-type: none"> Position the sample tray again and make sure it clicks into place. Initialize the analyzer.
Error code: Error message	115: Wrong rack
Cause	Remedy
<ul style="list-style-type: none"> The wrong sample tray is set in the software. 	<ul style="list-style-type: none"> Check the device configuration settings.. If necessary, set a different sample tray.
Error code: Error message	116: Unknown sampler command
Cause	Remedy
<ul style="list-style-type: none"> Communication error. 	<ul style="list-style-type: none"> Inform the service.
Error code: Error message	201: Restart the internal program
Cause	Remedy
<ul style="list-style-type: none"> Internal program error. 	<ul style="list-style-type: none"> Initialize the analyzer. For repeated occurrences, monitor precisely at which time the error occurs.
Error code: Error message	401: Syringe pump: Initialization 402: Syringe pump: invalid command 403: Syringe pump: invalid operand 404: Syringe pump: faulty command sequence
Cause	Remedy
<ul style="list-style-type: none"> Communication error. Syringe pump faulty. 	<ul style="list-style-type: none"> Initialize the analyzer. Inform the service.

Error code: Error message	409: Syringe pump: pump sluggish
Cause	Remedy
<ul style="list-style-type: none"> A hose line is clogged. 	<ul style="list-style-type: none"> Search for the cause and remedy the fault. Clean or replace the hose line. Initialize the analyzer.
<ul style="list-style-type: none"> Syringe pump faulty. 	<ul style="list-style-type: none"> Inform the service.
Error code: Error message	410: Syringe pump: valve sluggish
Cause	Remedy
<ul style="list-style-type: none"> Syringe pump faulty. The valve is broken. 	<ul style="list-style-type: none"> Inform the service.
Error code: Error message	415: Syringe pump: invalid command
Cause	Remedy
<ul style="list-style-type: none"> Communication error. 	<ul style="list-style-type: none"> Initialize the analyzer.
<ul style="list-style-type: none"> Syringe pump faulty. 	<ul style="list-style-type: none"> Inform the service.

7.2 Status errors

Status errors are displayed in the **Instrument status** device panel.

Error indication	In 140 ml/min; Out < 130 ml/min
Cause	Remedy
<ul style="list-style-type: none"> The MFM (mass flow sensor) is faulty. 	<ul style="list-style-type: none"> Check the flow with an external mass flow sensor if possible to confirm the error. Inform the service.
<ul style="list-style-type: none"> The filling of the halogen trap is used up. 	<ul style="list-style-type: none"> Check the halogen trap.
Error indication	In 140 ml/min; Out < 130 ml/min; Out > 150 ml/min
Cause	Remedy
<ul style="list-style-type: none"> No carrier gas. The hose line is leaking. 	<ul style="list-style-type: none"> Turn on the carrier gas on the pressure reducer. Search for and remedy the leak.
<ul style="list-style-type: none"> The inlet pressure of the carrier gas supply is too low. 	<ul style="list-style-type: none"> Set the carrier gas inlet pressure correctly.
<ul style="list-style-type: none"> The pressure switch in the analyzer was triggered simultaneously with error 10: Gas pressure error. 	<ul style="list-style-type: none"> See the remedy for 10: Gas pressure error.
<ul style="list-style-type: none"> The MFC is faulty. 	<ul style="list-style-type: none"> Inform the service.
Error indication	In < 140 ml/min; Out: 135 ... 145 ml/min
Cause	Remedy
<ul style="list-style-type: none"> No carrier gas. 	<ul style="list-style-type: none"> Turn on the carrier gas on the pressure reducer.
<ul style="list-style-type: none"> The inlet pressure of the carrier gas supply is too low. 	<ul style="list-style-type: none"> Set the carrier gas inlet pressure correctly.
<ul style="list-style-type: none"> The MFM is faulty. 	<ul style="list-style-type: none"> Inform the service.
Error indication	In 140 ml/min; Out > 150 ml/min
Cause	Remedy

<ul style="list-style-type: none"> ▪ Peltier cooling insufficient. 	<ul style="list-style-type: none"> ▪ Check the cooling from above on the TIC condensate container. The formation of condensation water on the cooling block indicates that the cooling is working.
<ul style="list-style-type: none"> ▪ The MFC is faulty. 	<ul style="list-style-type: none"> ▪ Inform the service.
Error indication	In; Out = 0 ml/min
Cause	Remedy
<ul style="list-style-type: none"> ▪ A hose line is clogged. 	<ul style="list-style-type: none"> ▪ Remove and rinse the clogged hose line. Reinstall it again afterward. ▪ Replace the clogged hose line.
<ul style="list-style-type: none"> ▪ No method loaded. 	<ul style="list-style-type: none"> ▪ Load a method.
Error indication	NDIR detector values highlighted in color in the Instrument status panel
<ul style="list-style-type: none"> ▪ The analog values of the detector are at the edge of the working range. 	<ul style="list-style-type: none"> ▪ Check the halogen trap. Replace the filling if necessary. ▪ Contact the application team and get tips on application regulations for difficult sample matrices.

You can continue measurement even if the analog values are displayed in yellow. The display notifies you that the detector is leaving the optimum working range.

The analog values slowly shrink due to aging. If the values drop after a few analyses, the analysis gas is probably causing damage to analyzer components.

7.3 Device errors

Error	Water traps clogged
Cause	Remedy
<ul style="list-style-type: none"> ▪ The service life of the water traps has elapsed. ▪ Measuring of samples with strong aerosol generation. 	<ul style="list-style-type: none"> ▪ Replace the water trap.
<ul style="list-style-type: none"> ▪ Peltier cooling insufficient. Message in the Instrument status panel that the temperature is outside of the range. 	<ul style="list-style-type: none"> ▪ Inform the customer service department.
Error	Initialization does not complete
Cause	Remedy
<ul style="list-style-type: none"> ▪ No flow can be detected at the system outlet. 	<ul style="list-style-type: none"> ▪ Open the pressure reducer on the carrier gas bottle. ▪ Check that the system (gas path) has been completely installed.
Error	UV lamp does not switch on during initialization
Cause	Remedy
<ul style="list-style-type: none"> ▪ The measuring gas flow is below the range of 140 ml/min. 	<ul style="list-style-type: none"> ▪ Check the gas flow, see Status errors.
Error	UV lamp switches off during operation
Cause	Remedy
<ul style="list-style-type: none"> ▪ The measuring gas flow drops below the minimum flow during measurement pauses. The UV lamps switches off for safety reasons. 	<ul style="list-style-type: none"> ▪ Check the gas flow, see Status errors.

<ul style="list-style-type: none"> Lamp does not switch on despite correct gas flow. UV lamp defective 	<ul style="list-style-type: none"> Inform customer service and have the UV module replaced.
Error	Minimum sample volume > vessel volume
Cause	Remedy
<ul style="list-style-type: none"> Selected sample volume too large. Number of measurements too high. 	<ul style="list-style-type: none"> Check and adjust the sample volume, flushing volume and number of determinations settings in the method.
Error	Flushing water insufficient (for sample feed with autosampler)
Cause	Remedy
<ul style="list-style-type: none"> Flushing reservoir insufficient. 	<ul style="list-style-type: none"> Check and adjust the flushing volume and number of flushes settings in the method.
Error	Scattering measurements
Cause	Remedy
<ul style="list-style-type: none"> Dosing faulty. The dosing syringe is leaky. 	<ul style="list-style-type: none"> Check the dosing. Ensure that samples are drawn in without bubbles. Check that enough sample is provided. Install a new dosing syringe.
<ul style="list-style-type: none"> Instable reagent addition. 	<ul style="list-style-type: none"> Ensure that reagents are drawn in without bubbles. Take the reagent blank value into account. Adjust the purge flow for reagents. Check that sufficient reagent is provided. Insert the hose further into the reservoir bottle.
<ul style="list-style-type: none"> Inhomogeneous samples. 	<ul style="list-style-type: none"> Filter samples prior to analysis. Stir samples prior to injection. To do this, use an autosampler with stirring function.
<ul style="list-style-type: none"> Sensitive samples can be affected by ambient air. 	<ul style="list-style-type: none"> Prevent the addition of CO₂ or organic vapors from the ambient air. Check the ambient conditions and remedy the source of the fault. Cover the sample vessels on the autosampler with aluminum foil. Treat the headspace of the sample with gas.
<ul style="list-style-type: none"> NDIR-based drift: Unsuitable integration criteria. The software ends measurement too early. 	<ul style="list-style-type: none"> Check the method settings. If necessary, increase the maximum integration time.
Error	Autosampler does not draw in sample without air bubbles
Cause	Remedy
<ul style="list-style-type: none"> The sample intake path is leaky. 	<ul style="list-style-type: none"> Check the hose connections. If necessary, tighten loose hose connections to the canula or to the valve of the syringe pump.
<ul style="list-style-type: none"> The sample intake canula is clogged. 	<ul style="list-style-type: none"> Remove the canula and clean it in an ultrasonic bath. Replace the canula.

<ul style="list-style-type: none"> ■ The dosing syringe is leaky. ■ The PTFE sealing lips of the plunger are damaged. 	<ul style="list-style-type: none"> ■ Remove and check the dosing syringe. ■ Replace the dosing syringe.
Error	Carry-over
Cause	Remedy
<ul style="list-style-type: none"> ■ Insufficient syringe flushing. 	<ul style="list-style-type: none"> ■ Flush the dosing syringe with sample before the next injection. To do this, edit the method in the Methods window and enter for measurement 1 "3" on the Replicates tab, all additional measurements do not require flushing. Here enter "0".
Error	Incomplete dosing in the reactors
Cause	Remedy
<ul style="list-style-type: none"> ■ The dosing path is leaky. 	<ul style="list-style-type: none"> ■ Check the hose connections. If necessary, tighten loose connections.
Error	Unusual peak shape
Cause	Remedy
<ul style="list-style-type: none"> ■ Incomplete sample digestion. 	<ul style="list-style-type: none"> ■ Add reagents. ■ Decrease sample volume. ■ Dilute samples.
Error	Leaking condensate pump
Cause	Remedy
<ul style="list-style-type: none"> ■ Leaking hose connections. ■ Defective pump hose. 	<ul style="list-style-type: none"> ■ Replace the pump hose.
Error	Control lamps on the analyzer do not light
Cause	Remedy
<ul style="list-style-type: none"> ■ Power supply or electronics fault. 	<ul style="list-style-type: none"> ■ Check the electrical connections. ■ Check the laboratory power supply.
<ul style="list-style-type: none"> ■ Device fuse faulty. 	<ul style="list-style-type: none"> ■ Inform the service.

8 Transport and storage

8.1 Transport

When transporting the device, observe the safety instructions in the "Safety instructions" section.

Avoid the following during transport:

- Impact and vibration
Risk of damage due to shock, impact or vibration!
- Large temperature fluctuations
Risk of condensation!

8.1.1 Preparing the analyzer for transport



CAUTION

Risk of injury

A risk of injury due to broken glass is present when handling glass parts.

- Handle glass parts with extreme caution.
- Wear non-slip glass handling gloves that allow a firm and secure grip.



NOTE

Risk of device damage due to unsuitable packaging material

- Only transport the device and its components in the original packaging.
- Empty the device completely and attach all transport locks before transporting the device.
- Add a suitable desiccant to the packaging to prevent damage from moisture.

Prepare the analyzer for transport as follows:

- ▶ Shut down the analyzer via the software.
- ▶ Switch off the analyzer via the main switch. Allow the device to cool down.
- ▶ Cut the gas supply. Disconnect the power plug from the power socket.
- ▶ Disconnect all cables and gas hoses on the rear of the analyzer.
- ▶ Open the doors of the analyzer.
- ▶ Remove the two reagent bottles, the drip trays and other loose accessories. Wipe off the hoses with a clean paper towel.
 - ⚠ CAUTION! The hoses contain residue from acids and reagents.
- ▶ Detach the canulas from the hoses. Put the canulas in the canula packaging.
 - 📘 NOTE! Package the canulas with care. The canulas may bend.
- ▶ Remove the hoses from the connections on the halogen trap. Remove the halogen trap from the clamps.
- ▶ Remove and empty the TIC condensate container.

- ▶ Pack open hose ends in protective bags and secure them in the analyzer, for example with adhesive tape.
- ▶ Close the front doors of the analyzer.
- ▶ Carefully package the accessories. Ensure that the glass components are packed to prevent breakage.
- ▶ Package the analyzer and the accessories in the original packaging.
 - ✓ The analyzer is securely packed for transport.

See also

📖 Maintenance and care [▶ 67]

8.1.2 Preparing the AS vario autosampler for transport



NOTE

Risk of device damage when transporting without transport locks

During transport without transport locks, the device can become damaged.

- Always apply a transport lock before transport.

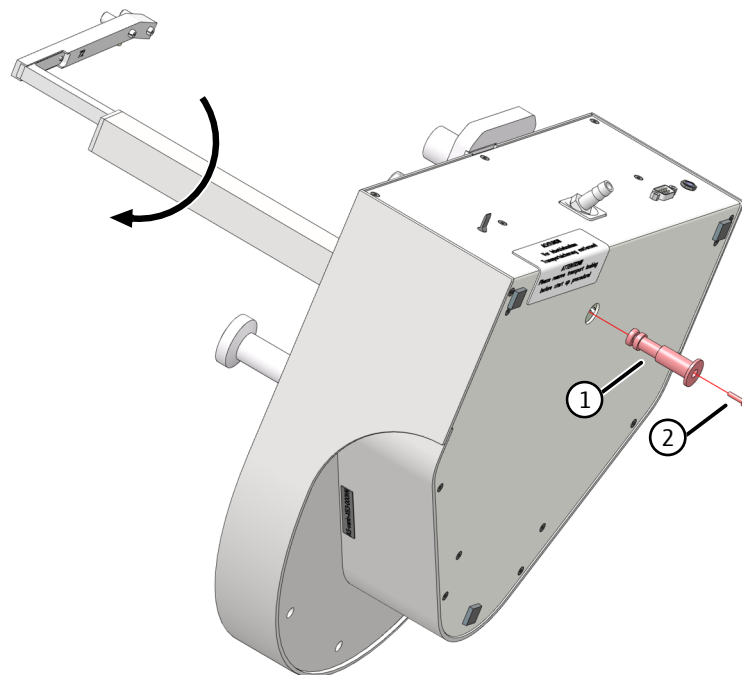

Fig. 50 Securing the autosampler for transport

1 Transport lock

2 M3x12 screw

- ▶ Turn the autosampler on its side and put it down safely.
- ▶ Turn the autosampler arm clockwise up to the stop.
 - ✓ The drives are in the correct position.
- ▶ Slide the transport lock into the opening of the bottom plate up to the stop.
- ▶ Fasten the transport lock with the screw and the supplied hexagon socket key.
- ▶ Put the autosampler into its original packaging.
 - ✓ The autosampler can now be safely transported.

8.1.3 Moving the device in the laboratory



CAUTION

Risk of injury during transport

Dropping the device poses a risk of injury and damage to the device.

- Proceed carefully when moving and transporting the device. Two persons are required to lift and carry the device.
- Grip the device firmly at the bottom with both hands and lift it simultaneously.

Observe the following when moving the device within the laboratory:

- Insufficiently secured components pose a risk of injury!
Before moving the device, remove all loose parts and disconnect all connections from the device.
- For safety reasons, two persons are required to transport the device, one person on each side of the device.
- As the device does not have carrying handles, grip the device firmly with both hands at the lower end. Lift the device simultaneously.
- Observe the guide values and adhere to the legally mandated limits for lifting and carrying loads without auxiliary means.
- Observe the installation conditions at the new location.

8.2 Storage



NOTE

Risk of device damage due to environmental conditions

Environmental influences and condensation can destroy individual components of the device.

- Only store the device in air-conditioned rooms.
- Ensure that the atmosphere is free of dust and corrosive vapors.

If the device is not installed immediately after delivery or not required for longer periods, it should be stored in its original packaging. A suitable desiccant should be added to the equipment to prevent damage from moisture.

The requirements for the climatic conditions of the storage location can be found in the specifications.

9 Disposal

Waste water	Waste water containing acids and samples occurs during device operation. Dispose of the neutralized waste in accordance with the legal requirements.
Halogen trap	The halogen trap contains copper and brass. Contact the responsible institution (authority or waste disposal company). There you will receive the information regarding recycling or disposal.
Analyzer	At the end of its service life, the device and its electronic components must be disposed of as electronic waste in accordance with the applicable regulations.

9.1 Disposing of the UV module

The UV module is equipped with a low-pressure mercury vapor lamp. Remove the UV module from the analyzer for disposal. Dispose of the UV module in accordance with the national regulations for lamps that contain mercury.

Removing the UV module



WARNING

Risk of electric shock

Lethal electrical voltages occur in the UV module of the analyzer. Touching the UV module with the device switched on can be fatal.

- Before opening the side wall, switch off the analyzer via the main switch and disconnect the mains plug from the power outlet.



CAUTION

Risk of burns on the UV module

The UV reactor remains hot immediately after switching off the device.

- Wait at least 30 min for the UV reactor to cool down before removing the UV module.

Preparation:

- ▶ Exit the software. Switch off the analyzer via the main switch. Disconnect the power plug from the power socket. Cut the gas supply.
- ▶ Switch off the autosampler. Remove the power cable and the serial data cable on the autosampler. Remove the autosampler.
- ▶ Remove the hoses from the ultrapure water bottle, the reagent bottles and the sample vessel. Wipe off the hoses.
- ▶ Remove the reagent bottles and drip trays from the analyzer.
- ▶ Wait until the UV module has cooled down.

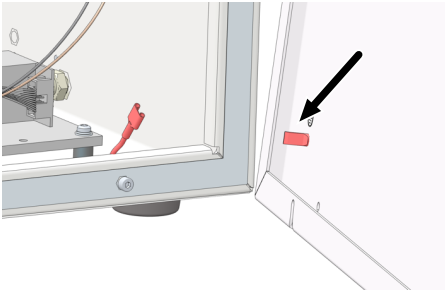

- ▶ Remove the right side wall of the analyzer.
- ▶ Unscrew the four attachment screws for this. The screws are captive and remain attached to the wall.
- ▶ Remove the protective grounding (see arrow). Set the side wall aside safely.
- ✓ The UV module is now accessible for removal.

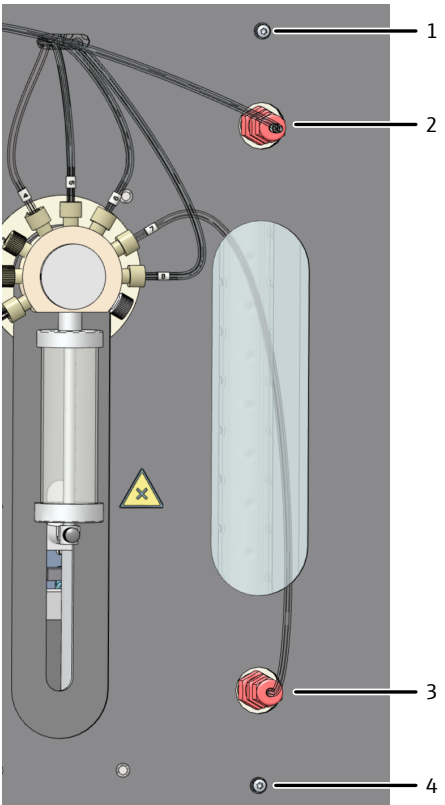

- ▶ Remove hoses 7 and 19 from the PTFE screw connections. (2 and 3 in the image: Hoses to the UV module 1 and 4 in the image: UV module attachment screws)

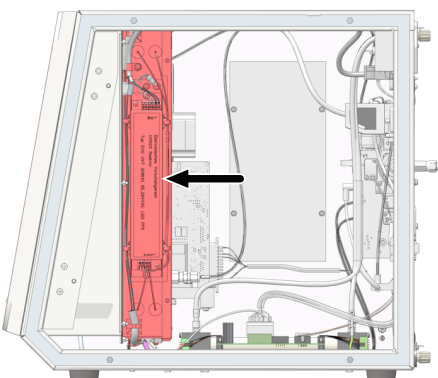

- ▶ Hold the UV module in the interior of the analyzer with your right hand.

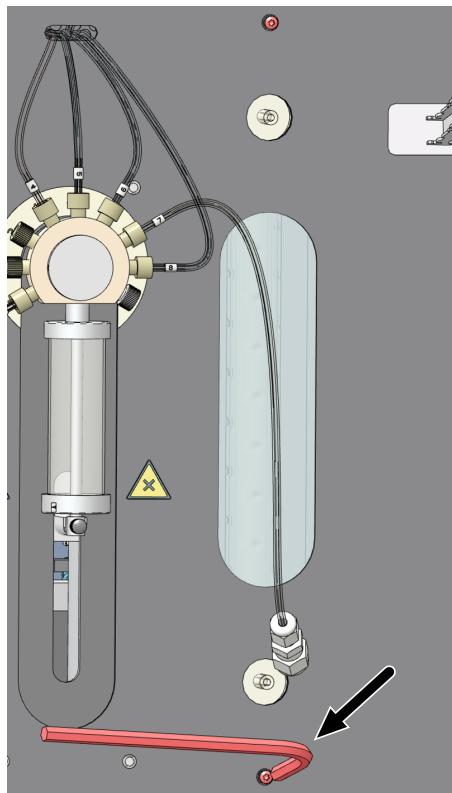

- ▶ Unscrew the two attachment screws above and below the UV protection glass with your left hand.

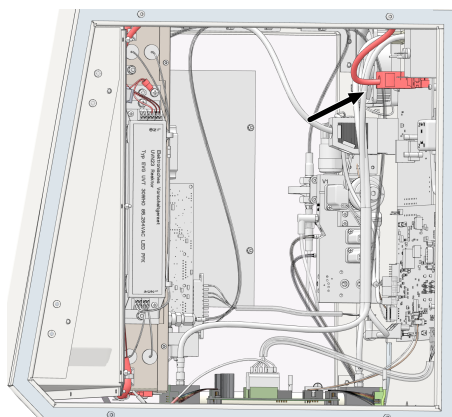

- ▶ Remove the complete UV module from the analyzer toward the rear and to the right.
- ▶ Pull the plug-in connector out of the connection in the analyzer (see arrow).

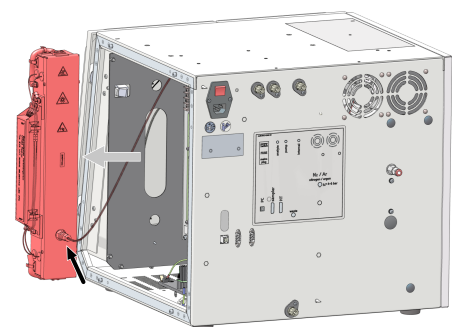

- ▶ Detach hose 23 from the PTFE screw connection on the UV module.
 - ✓ The UV module is removed and can be properly disposed of.

10 Specifications

10.1 Technical data of the basic device

General characteristics	Designation/type	multi N/C 4300 UV
	Item number	11-0118-301-62
	Basic device dimensions (W x D x H)	513 x 547 x 464 mm
	Basic device mass	18 kg
	Sound pressure level	<70 dB(A)
Methods data	Digestion principle	Wet chemical UV oxidation at 185 nm; 254 nm with Na ₂ S ₂ O ₈ as oxidant
	Measuring methods	TC, TIC, TOC (differential method), NPOC, DOC
	Temperature of the measuring medium	80 °C
	Sample feed	Flow injection
	Sample volume	50 to 20000 µl
	Particle handling capacity	In accordance with DIN EN 1484
	Carbon detection principle	NDIR (coupled with the VITA method)
	TC, TOC, NPOC, TIC measurement range	0 to 10000 mg/l
	TC, TOC in solid measurement range (with the HT 1300 solids module)	0 to 500 mg
	Process control	Control and analysis software
Software function scope		Real-time graphics, status indication during analysis, graphical display of the measured results, result print-out Optional FDA 21 CFR Part 11 Compliance module for data integrity and compliance with the pharmaceutical guidelines 21 CFR Part 11.
Gas supply	Option 1	Nitrogen ≥5.0
	Option 2	Purified nitrogen (≥5.0) provided by a TN gas generator CO ₂ <1 ppm Hydrocarbons: TOC quality
	Option 3	Argon ≥4.6
	Inlet pressure	400 to 600 kPa
	Inlet pressure (gas supply via gas generator)	300 to 600 kPa
	Flow rate	15 l/h
	Analyte gas flow	140 ml/min
	NPOC purge flow	100 ml/min

Electrical variables	Voltage	100 to 240 V
	Frequency	50/60 Hz
	Fuses	2 T4 A H
	Typical average power consumption	150 VA
	Maximum power consumption	200 VA
	PC interface	USB 2.0
	Module/accessory interface	RS 232

Only use original fuses from Analytik Jena!

Ambient conditions	Operating temperature	+10 to 35 °C (air-conditioning recommended)
	Maximum humidity	90 % at 30 °C
	Air pressure	0.7 to 1.06 bar
	Storage temperature	5 to 55 °C
	Humidity during storage	10 to 30 % (use desiccant)
	Operating altitude (max.)	2000 m

Control computer minimum requirements	Processor	Comparable with Intel Core i5/AMD Ryzen 5 series
	Disk drive	Min. 64 GB
	RAM	Min. 8 GB
	Screen resolution	Min. 1920 x 1080 px
	Graphics card	compatible with DirectX 12 or higher
	USB port	Min. 1 USB 2.0 interface, to connect the basic device
	CD/DVD drive	For software installation
	Operating system	Windows 10/11

The optional FDA 21 CFR Part 11 Compliance module requires a server for the central CDM service in the local, in-house network that meets the following minimum requirements. Alternatively, if there is only one client you can install the CDM server on the control computer.

Processor	Min. 4 cores (Quad Core)
Disk drive	≥100 GB
RAM	Min. 8 GB

10.2 Technical data of the accessories

AS 21hp, AS 10e autosamplers	Order number (designation)	11-0513-001-26 (AS 21hp) 11-0516-003-26 (AS 10e)
	Dimensions (W x D x H), without holder	260 x 320 x 390 mm
	Mass	4.5 kg
	Operating voltage	24 V DC, 2.5 A via external power supply
	Power supply of power supply unit	110 to 240 V +10/-5 %, 50/60 Hz:

	Power consumption	60 VA		
AS 21hp autosampler	Sample positions	21		
	Tube size	50 ml		
	Purging NPOC samples	Parallel and sequential		
	Magnetic stirrer (integrated)	Homogenization of samples containing particles		
AS 10e autosampler	Sample positions	10		
	Tube size	50 ml		
	Purging NPOC samples	Sequential only		
AS vario autosampler	Order number (designation)	11-0514-003-26 (AS vario)		
	Order number (designation)	11-0514-004-26 (AS vario ER with cannula flush)		
	Dimensions (W x D x H)	350 x 400 x 470 mm		
	Mass	15 kg		
	Operating voltage	24 V DC via external power supply		
	Power supply, external power supply unit	100 to 240 V, 50/60 Hz (autosensing)		
	Power consumption	50 VA		
	Sample tray with sample positions	Tube size	AS vario	AS vario ER
	20	100 ml	Yes	No
	47 (dilut)	12 ml + 50 ml	Yes	Yes
	52	100 ml	Yes	No
	72	40 ml + 50 ml (optional)	Yes	Yes
	100	20 ml	Yes	Yes
	146	12 ml	Yes	Yes
EPA Sampler	Order number (designation)	11-126.693 (EPA Sampler)		
	Dimensions (W x D x H)	500 x 540 x 550 mm		
	Mass	15 kg		
	Operating voltage	24 V DC via external power supply		
	Power supply, external power supply unit	100 to 240 V, 50/60 Hz (autosensing)		
	Power consumption	30 VA		
	Sample positions	64		
	Sample vessels	40 ml		

The ambient conditions for operation and storage of the accessories correspond to the ambient conditions of the basic device.

The technical data for other accessories can be found in their separate operating instructions.

10.3 Standards and directives

Protection class and protection type	The device is protection class I and protection type IP 20.
Device safety	<p>The device complies with the following safety standards</p> <ul style="list-style-type: none">▪ EN 61010-1▪ EN 61010-2-081▪ EN 61010-2-051 (for operation with autosampler)
EMC compatibility	<p>The device has been checked for transient emissions and noise immunity.</p> <ul style="list-style-type: none">▪ The device meets the requirements for transient emissions according to EN IEC 61326-1 (EN 55011 Group 1, Class B).▪ The device meets the requirements for interference immunity according to EN IEC 61326-1 (requirements for use in basic and industrial electromagnetic environments).
Environmental and ambient influences	<p>This device has been tested in environmental simulations under operation and transport conditions and is in accordance with the requirements in:</p> <ul style="list-style-type: none">▪ ISO 9022-2▪ ISO 9022-3
EU directives	<p>The device meets the requirements of the directive 2011/65/EU.</p> <p>The device is designed and tested in accordance with standards meeting the requirements of EU directives 2014/35/EU and 2014/30/EU. The device leaves the factory in a sound condition with regard to technical safety. To maintain this condition and to ensure safe operation, the user must strictly observe the safety and operating instructions contained in this operating manual. For accessories delivered with the device and system components from other manufacturers, the information provided in their respective operating manuals has priority.</p>
Guidelines for China	<p>The device contains substances subject to regulation (according to the directive GB/T 26572-2011). Analytik Jena guarantees that, if the device is used as intended, these substances will not leak within the next 25 years and therefore will not pose a threat to the environment or health within this time period.</p>

List of figures

Fig. 1	Analyzer with open front.....	15
Fig. 2	Syringe pump	16
Fig. 3	Hose diagram	17
Fig. 4	FAST connector	17
Fig. 5	Fingertight screw connection	18
Fig. 6	Setting the NPOC purge flow and reagents purge flow	18
Fig. 7	Condensate pump	19
Fig. 8	UV reactor with control gear (right-hand side wall open).....	19
Fig. 9	TIC condensation module	20
Fig. 10	Water traps.....	21
Fig. 11	Halogen trap.....	21
Fig. 12	Status LED	22
Fig. 13	Device rear.....	23
Fig. 14	Principle of operation	25
Fig. 15	Space required for multi N/C 4300 UV with modules	35
Fig. 16	Device rear.....	37
Fig. 17	AS 10e autosampler	40
Fig. 18	AS 21hp autosampler	41
Fig. 19	Parallel purging (left) and sequential purging (right)	42
Fig. 20	Autosampler attached to the analyzer by means of the holder	42
Fig. 21	Connections on the bottom of the autosampler	43
Fig. 22	Attaching the AS 21hp autosampler to the holder	44
Fig. 23	Fingertight connection.....	45
Fig. 24	Parallel purging (left) and sequential purging (right)	46
Fig. 25	Layout of the AS vario autosampler	48
Fig. 26	Layout of the AS vario ER autosampler	49
Fig. 27	Transport lock.....	49
Fig. 28	Sleeve with two canulas for non-parallel purging	50
Fig. 29	Fingertight connection.....	51
Fig. 30	Canula flush on the AS vario ER model	52
Fig. 31	EPA Sampler autosampler	53
Fig. 32	Rear of the autosampler.....	54
Fig. 33	Electrical connections	54
Fig. 34	Transport lock.....	55
Fig. 35	Installing the stirring arm	55
Fig. 36	Canula position for NPOC measurement with parallel (left) and non-parallel (right) purging.	56
Fig. 37	Fingertight connection.....	57
Fig. 38	Connections on the backplate of the solids module	58
Fig. 39	Adjustment points on the sample tray	69

Fig. 40	Sampler alignment window	69
Fig. 41	Install canulas (here: 2 canulas for parallel purging)	71
Fig. 42	Adjusting position 1	72
Fig. 43	Setting the NPOC purge flow	73
Fig. 44	Syringe pump maintenance.....	74
Fig. 45	FAST connector, angled.....	77
Fig. 46	Replacing the Fingertight connection.....	78
Fig. 47	Replacing the water traps on the front side	81
Fig. 48	Replacing the water traps on the gas box	82
Fig. 49	Replacing the halogen trap	84
Fig. 50	Securing the autosampler for transport.....	94